

BRITISH WWII FIGHTER 1:48 SCALE PLASTIC KIT



intro

The air war of World War II was, with some exceptions, a war of monoplanes. Their dawn came on just as the first shots of the Second World War began to ring out. The era of the biplane was coming to its end by the late thirties, notably in the fighter role. Nevertheless, some of these 'Last Mohicans' played their part in WWII, and in no negligible measure, either. The Gloster Gladiator was certainly one of them.

Development of the Gladiator commenced as a private venture of Gloster Aviation, in an attempt to further improve on the existing Gauntlet. With numerous changes, including, at the time, an unusual enclosed cockpit, chief designer Harry P Folland managed to better the flight characteristics to such an extent that the RAF took notice. As a result, the RAF ordered production in 1936, the decision being heavily influenced by the fact that the development of modern monoplanes was still ongoing at a time when the political situation in Europe had started to deteriorate rapidly. Under such conditions, the RAF opted for an interim solution with a biplane, obsolete at the time, but with rather acceptable performance figures. Although limited in speed and firepower, Gladiator pilots were able to fight not only similarly outdated Italian or Russian planes, but also modern German planes like the Heinkel He 111 or Messerschmitt Bf 110. It was not unusual for Gladiator pilots to expend all their rounds of ammunition to gain a victory. Among the most interesting incidents, the victory of Gideon Carlsson, a Swedish volunteer, over a huge Russian TB-3 bomber during the Winter War in Finland deserves mention.

Shortly after the production of the Mk.I version began, the Mk.II was on the board, sporting a three blade Fairey Reed prop instead of the two blade Watts unit. The Mercury Mk.IX engine was replaced by the Mk.VIII version of the same rating, but the maximum speed increased a little due to the new propeller. Also, the instrument panel changed.

Gladiator pilots were especially satisfied with the aircraft's maneuverability and stability while firing, although the armament, consisting of four small caliber 7.7 mm machine guns, was insufficient. The first 60 series Mk.Is received two Vickers Mk.V guns mounted in the sides of the fuselage and two Lewis guns under the lower wings. After that, four Vickers Mk.Vs became standard, later being replaced by more powerful Brownings of the same caliber.

The Sea Gladiator came as a development of the Mk.II. The first batch of planes, being considered 'interim', featured a strengthened fuselage and tail hook. A housing for a dinghy and pilot emergency supplies was added to the Sea Gladiator Mk.II. Although Sea Gladiators were to be equipped with a three bladed propeller, about half of them later received the two blade Watts type which suited operations from carrier decks better, since the plane was able to achieve a shorter take off run and had a faster initial climb rate.

Production of all versions of the Gloster Gladiator totaled 746 units, in service with not less than 21 air forces during pre war and war time periods.

úvodem

Druhá světová válka byla z leteckého pohledu až na několik výjimek válkou jednoplošníků, jejichž nástup na scénu se víceméně kryl s prvními válečnými výstřely. Éra dvouplošníků se nachýlila ke konci již ve druhé polovině třicátých let, a to především u stíhacích letounů. Přesto se několik „posledních Mohykánů“ zúčastnilo bojů v poměrně významné míře a Gloster Gladiator je jedním z nich.

Gladiator vznikl jako soukromá iniciativa továrny Gloster, která se rozhodla dále vylepšit typ Gauntlet. Šéfkonstruktor Harry P. Folland dokázal řadou změn, včetně v té době nezvyklé uzavřené kabiny, dostat z nového dvouplošníku výkony, které RAF zaujaly natolik, že nakonec v roce 1936 objednala sériovou výrobu. Rozhodnutí ovlivnil i fakt, že nové výkonnější jednoplošníky byly stále ještě ve vývoji a politická situace v Evropě se povážlivě zhoršovala. RAF tedy vzala zavděk i v té době již zastaralým, nicméně poměrně výkonným dvouplošníkem, který následně navzdory svým limitům v maximální rychlosti či palebné síle dokázal relativně účinně zasáhnout nejen proti podobně zastaralým italským či sovětským strojům, ale v řadě případů i proti moderním německým typům jako Heinkel He 111 či Messerschmitt Bf 110. Nezřídka museli piloti Gladiatorů do takového protivníka vyprázdnit všechny zásobníky svých kulometů, aby dosáhli sestřelu. Mezi nejzajímavější události patří sestřel ruského čtyřmotorového bombardéru TB-3, jenž si připsal během Zimní války švédský dobrovolník Gideon Carlsson.

Krátce po náběhu výroby verze Mk.I byla připravena vylepšená verze Mk.II, jež se vizuálně od svého předchůdce odlišuje zejména třílístou vrtulí Fairey Reed, která nahradila dřevěnou dvoulístou vrtuli Watts. Změnila se také podoba přístrojové desky. Motor Mercury Mk.IX byl nahrazen verzí Mk.VIII. Motory měly shodný výkon, Gladiator Mk.II ovšem dosahoval díky třílísté vrtuli s větším stoupáním o něco vyšší maximální rychlosti. Piloti si na Gladiatoru cenili především jeho vynikající obratnosti a zároveň stability při střelbě. Pro tu měli k dispozici čtveřici kulometů ráže 7,7 mm. Nejprve byly stroje dodávány s kombinací dvou trupových kulometů Vickers Mk.V a dvou křídelních Lewis, poté dostala část strojů také na křídelní pozice Vickersy. Obě zbraně byly později nahrazeny výkonnějšími licenčními Browningy stejné ráže.

Z Gladiatoru Mk.II byl vyvinut Sea Gladiator určený pro službu na letadlových lodích. První provedení, označované Interim, dostalo zesílenou konstrukci trupu a sklopný přístávací hák. Na něj navázala verze Sea Gladiator Mk.II, která již měla pod trupem mezi podvozkovými nohama pouzdro se záchranným člunem a nouzovou dávkou pro pilota. Sea Gladiatory byly dodávány s třílístou kovovou vrtulí, zhruba polovina jich však byla následně u jednotek vybavena dvoulístou vrtulí Watts s vyvažitelným nábojem. Důvodem byl kratší vzlet a rychlejší počáteční stoupání.

Celkem bylo vyrobeno 746 Gladiatorů všech verzí, které sloužily v ne méně než 21 letectvech během předválečného a válečného období.

ATTENTION



UPOZORNĚNÍ



ACHTUNG



ATTENTION



注意



Carefully read instruction sheet before assembling. When you use glue or paint, do not use near open flame and use in well ventilated room. Keep out of reach of small children. Children must not be allowed to suck any part, or pull vinyl bag over the head.



Před započatím stavby si pečlivě prostudujte stavební návod. Při používání barev a lepidel pracujte v dobře větrané místnosti. Lepidla ani barvy nepoužívejte v blízkosti otevřeného ohně. Model není určen malým dětem, mohlo by dojít k požití drobných dílů.

INSTRUCTION SIGNS * INSTR. SYMBOLS * INSTRUKTION SINNBILDEN * SYMBOLES * 記号の説明

OPTIONAL
VOLBABEND
OHNOUTOPEN HOLE
VYVRTAT OTVORSYMMETRICAL ASSEMBLY
SYMETRICKÁ MONTÁŽREMOVE
ODŘÍZNOUTREVERSE SIDE
OTOČITAPPLY EDUARD MASK
AND PAINT
POUŽÍT EDUARD MASK
NABARVIT

PARTS



DÍLY



TEILE



PIÈCES



部品

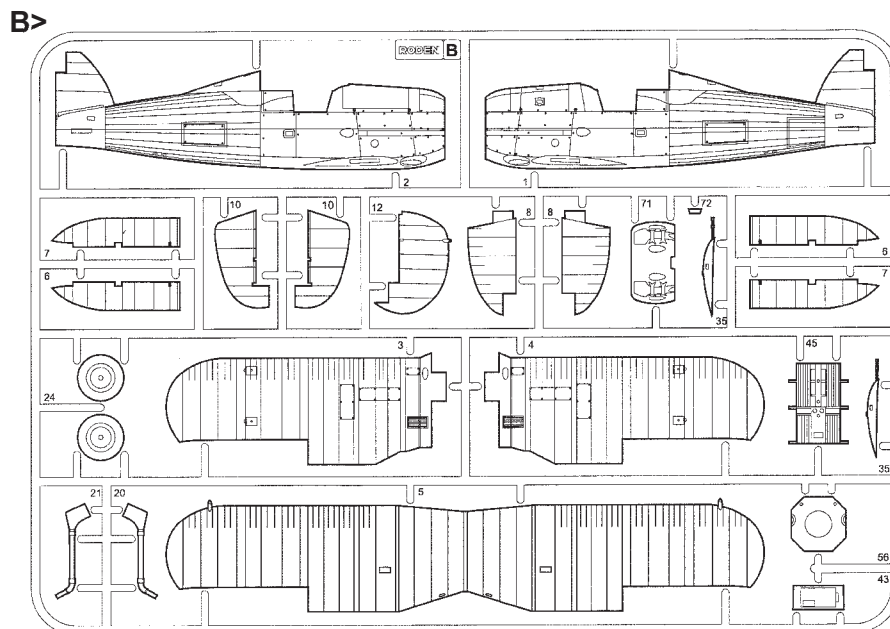
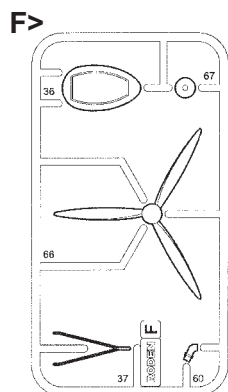
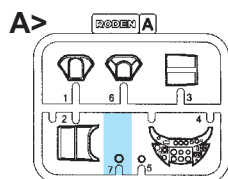

PLASTIC PARTS

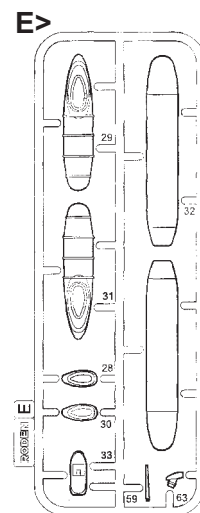
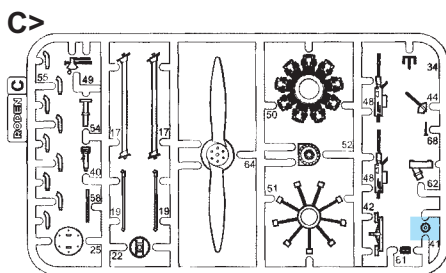
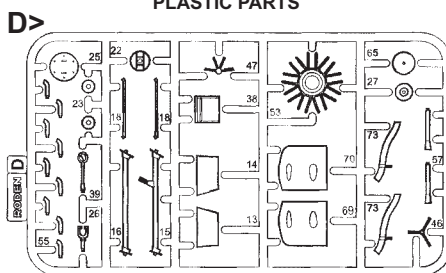

PE - PHOTO ETCHED DETAIL PARTS

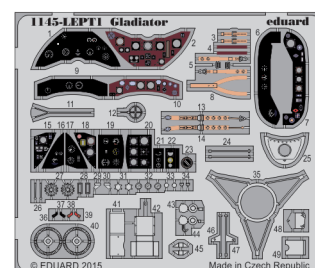
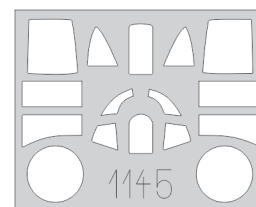
eduard
MASK

-Parts not for use. -Teile werden nicht verwendet. -Pièces à ne pas utiliser. -Tyto díly nepoužívejte při stavbě. - 使用しない部品

COLOURS



BARVY



FARBEN



PEINTURE



色

| GSI Creos (GUNZE) | | |
|-------------------|----------|------------|
| AQUEOUS | Mr.COLOR | |
| H 3 | C3 | RED |
| H 4 | C4 | YELLOW |
| H 6 | C6 | GREEN |
| H 8 | C8 | SILVER |
| H 11 | C62 | FLAT WHITE |
| H 12 | C33 | FLAT BLACK |
| H 25 | C34 | SKY BLUE |
| H 33 | C81 | RUSSET |
| H 37 | C43 | WOOD BROWN |

| AQUEOUS | Mr.COLOR | |
|---------|----------|----------------|
| H 47 | C41 | RED BROWN |
| H 53 | C13 | NEUTRAL GRAY |
| H 58 | C27 | INTERIOR GREEN |
| H 71 | C21 | MIDDLE STONE |
| H 72 | C22 | DARK EARTH |
| H 73 | C23 | DARK GREEN |
| H 75 | C25 | DARK SEAGRAY |
| H 77 | C137 | TIRE BLACK |
| H 80 | C54 | KHAKI GREEN |
| H 82 | C31 | DARK GRAY |

| AQUEOUS | Mr.COLOR | |
|----------------|----------|--------------------|
| H 303 | C303 | GREEN |
| H 324 | C324 | LIGHT GRAY |
| H 325 | C325 | GRAY |
| H 330 | C330 | DARK GREEN |
| H 333 | C333 | EXTRA DARK SEAGRAY |
| Mr.METAL COLOR | | |
| MC211 | | CHROME SILVER |
| MC214 | | DARK IRON |
| MC218 | | ALUMINIUM |
| MC219 | | BRASS |

A MARKINGS **A, G, H**

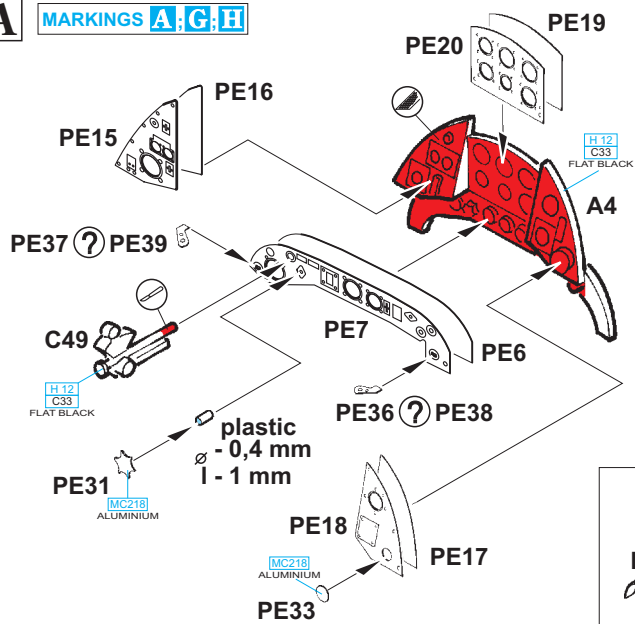

MARKINGS **B, C, D, E, F**

glue on the edge only

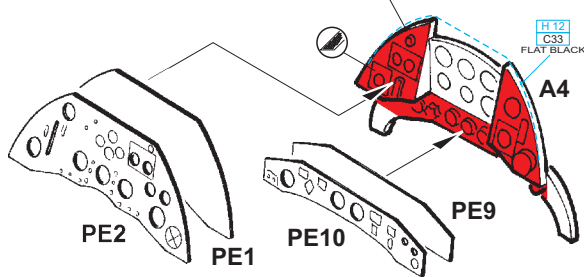

2 pcs.

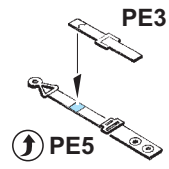

B

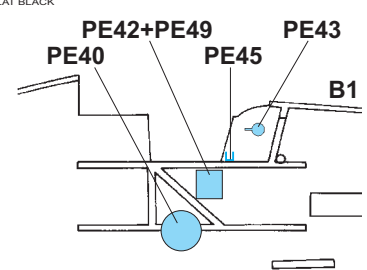
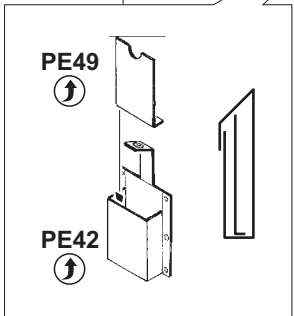
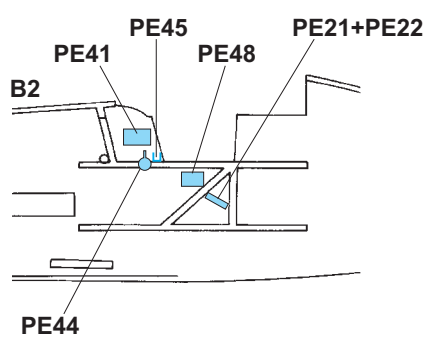
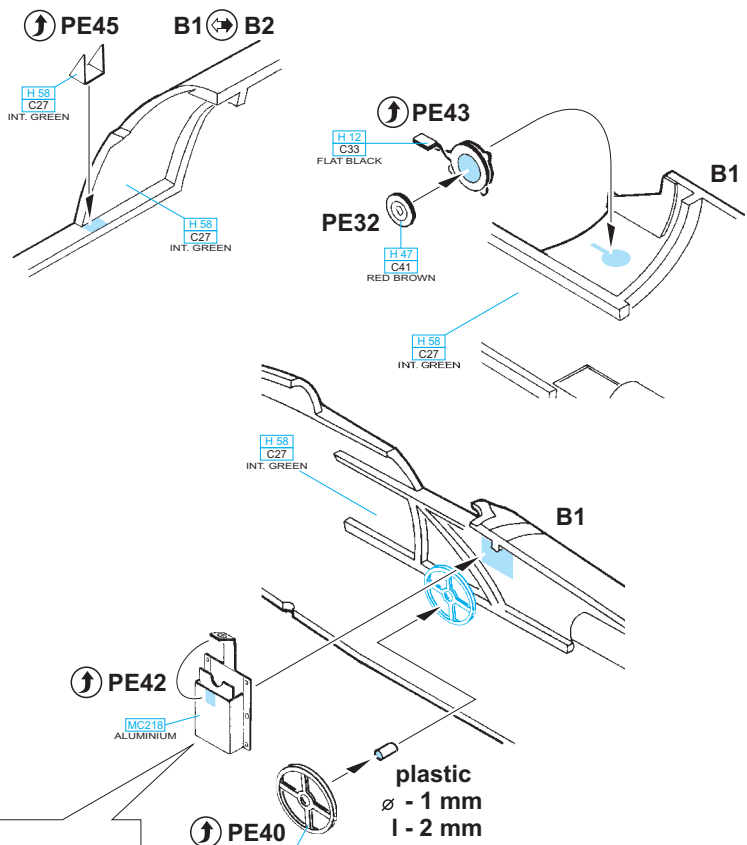
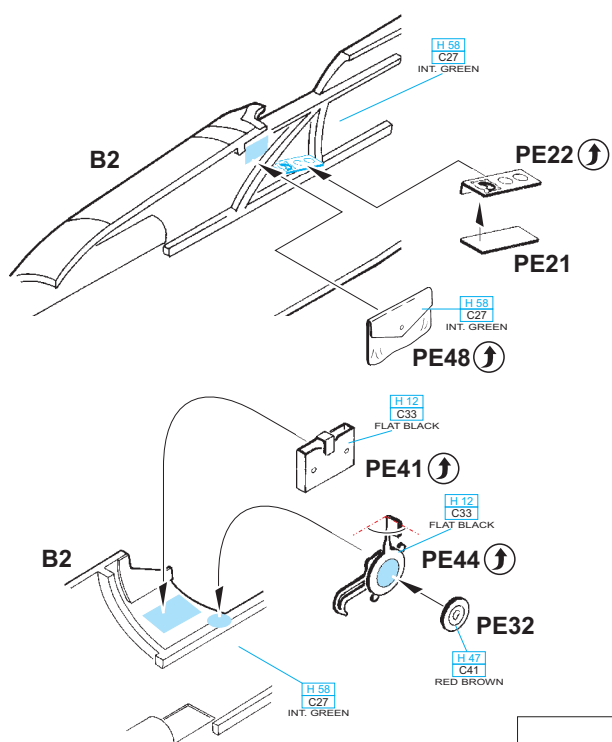
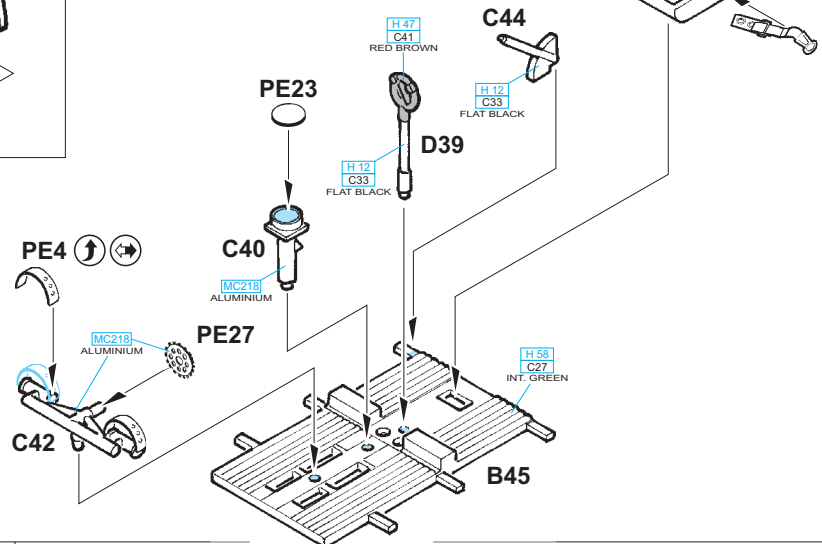

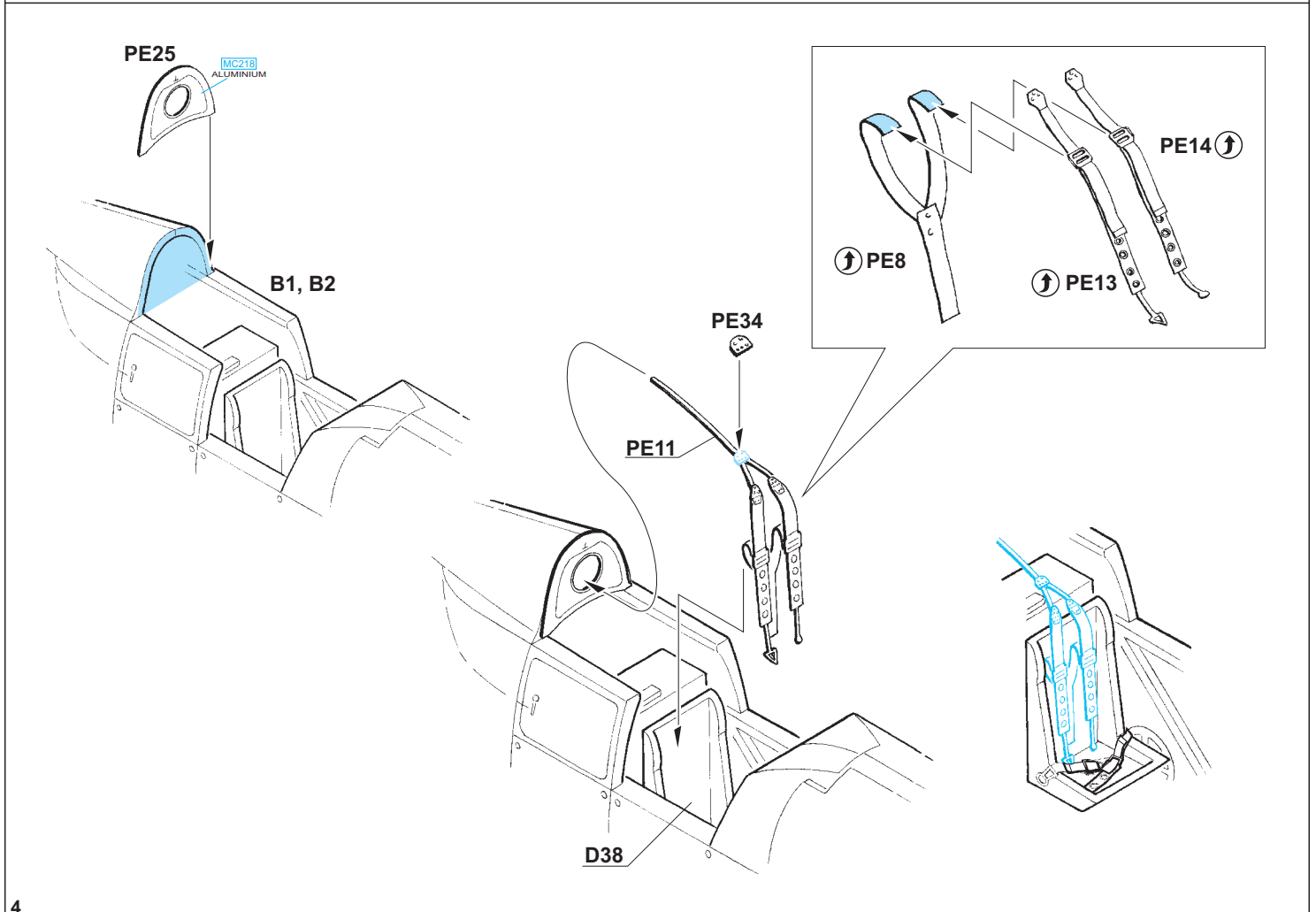
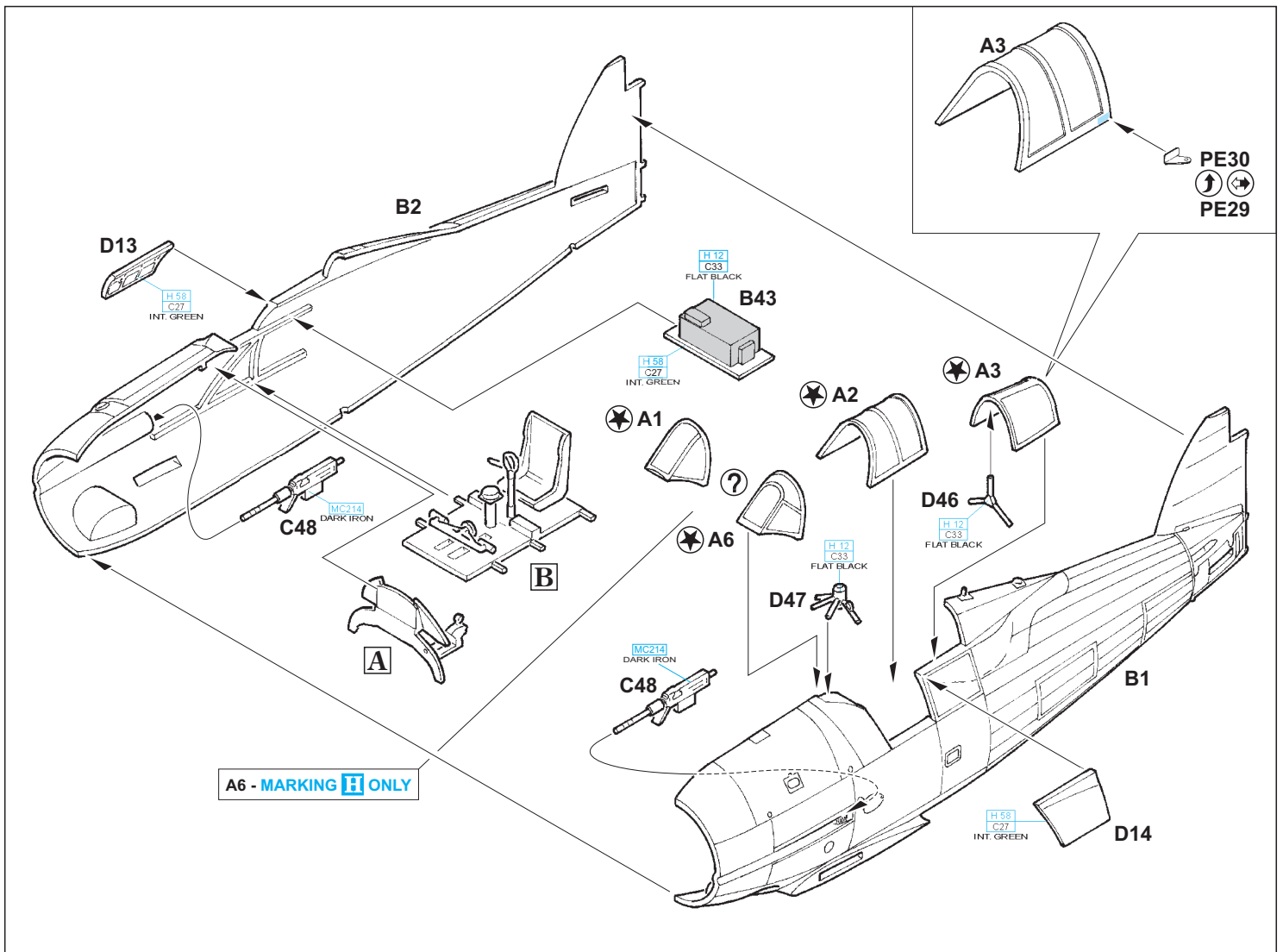

B24
2 pcs.

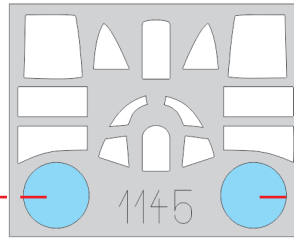
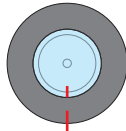

B24
2 pcs.

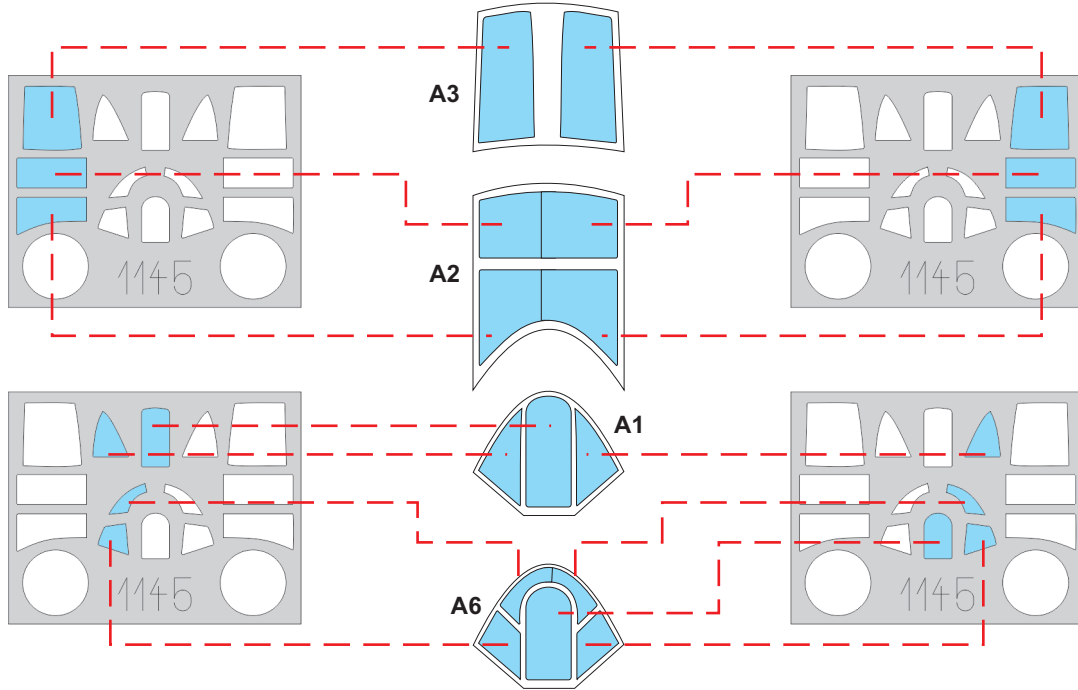
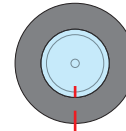

C

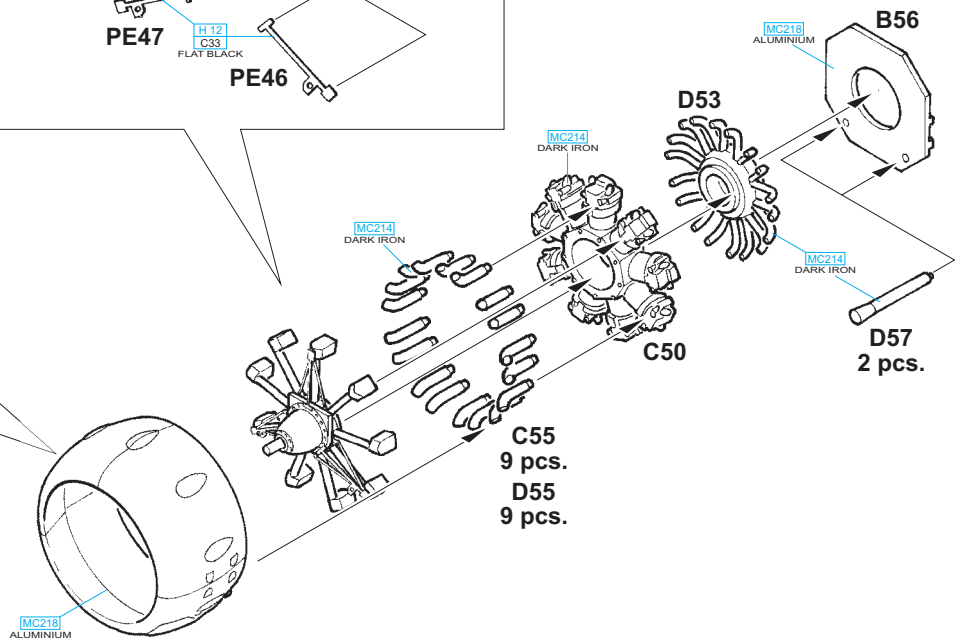
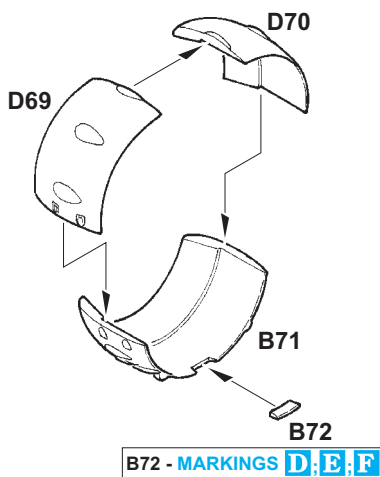
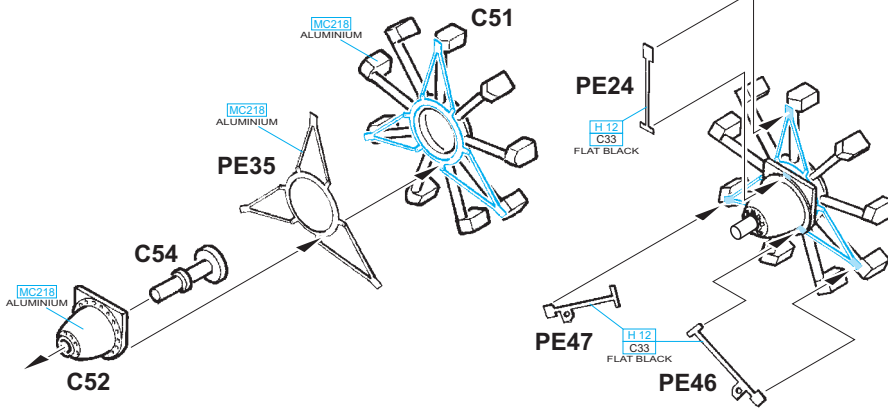

D 2 pcs.

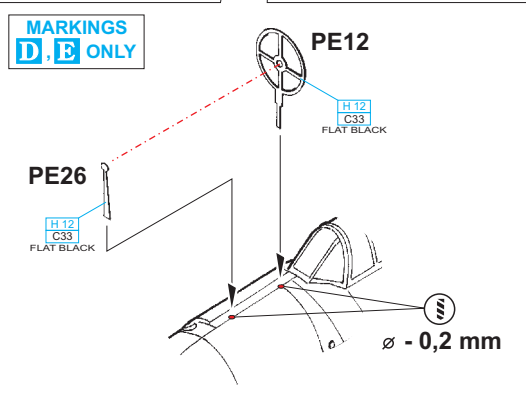
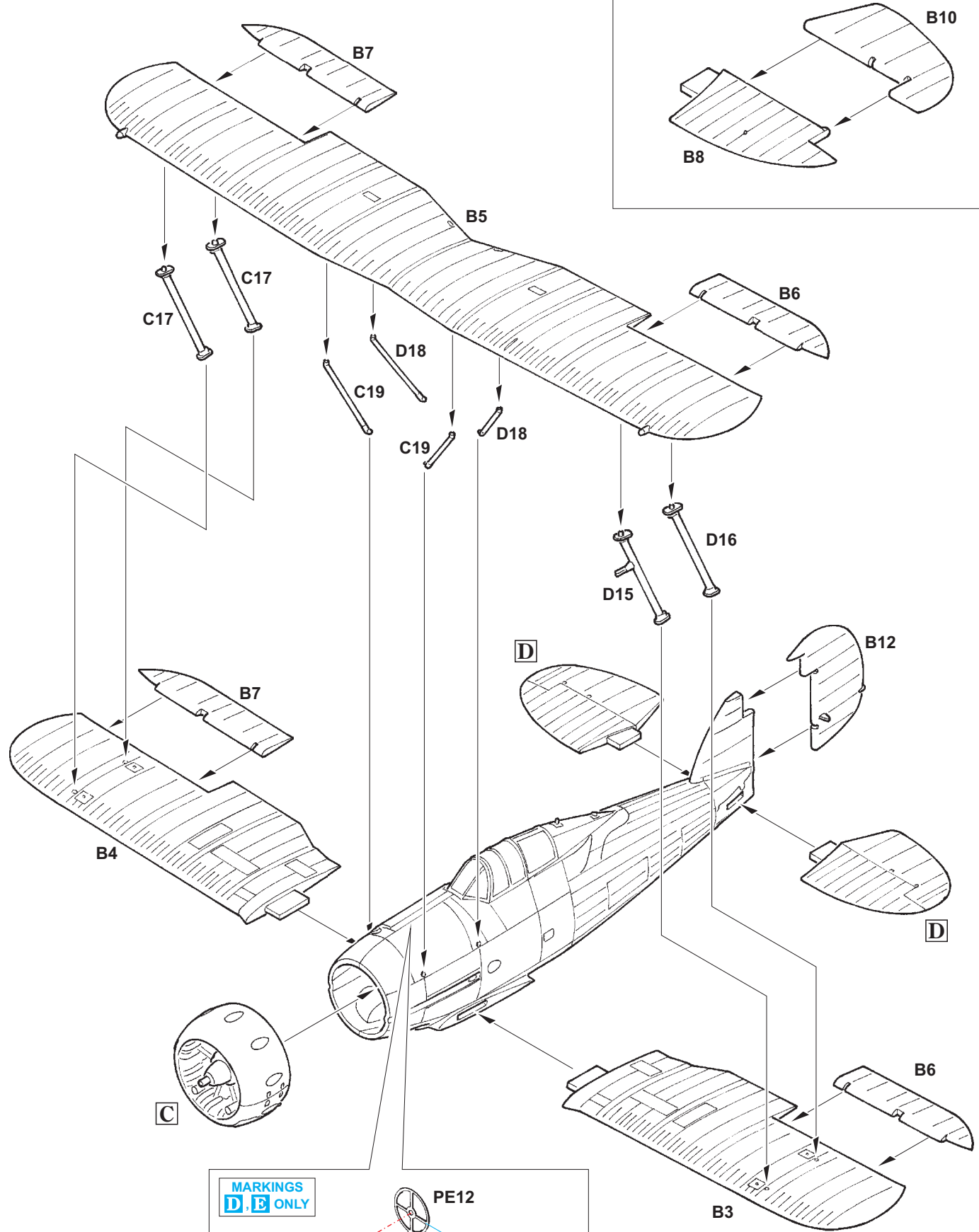

R L

MARKING B ONLY

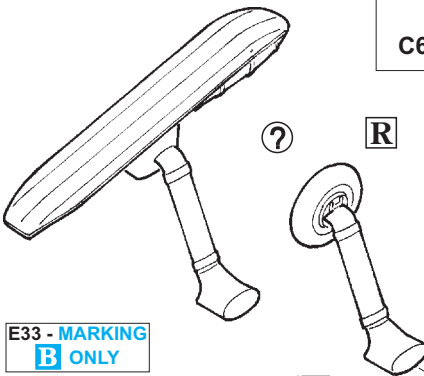
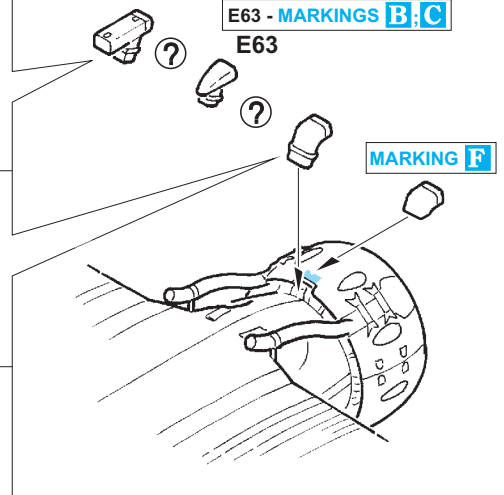
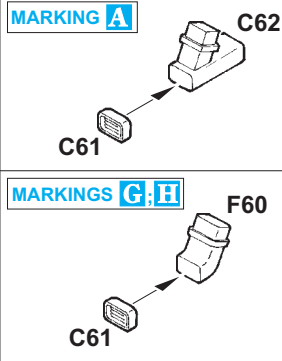
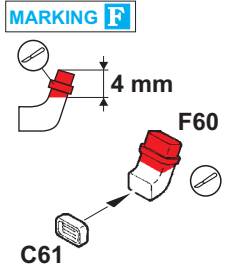
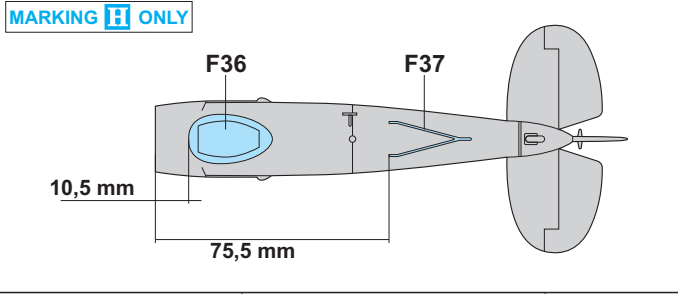
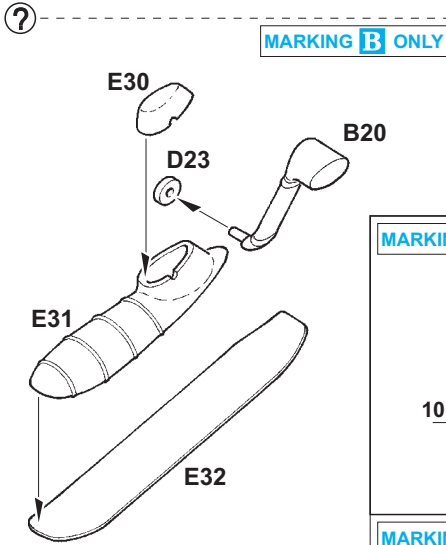
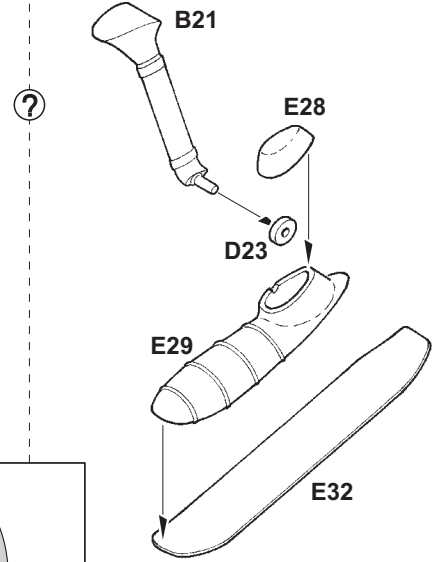
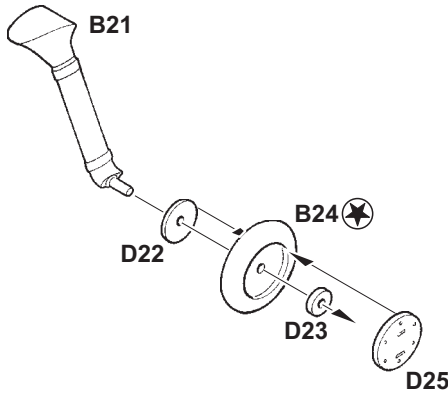
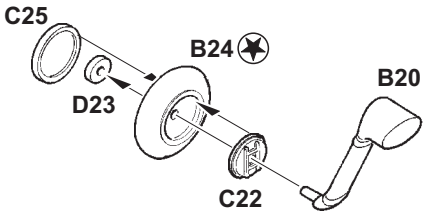

E33 - MARKING B ONLY

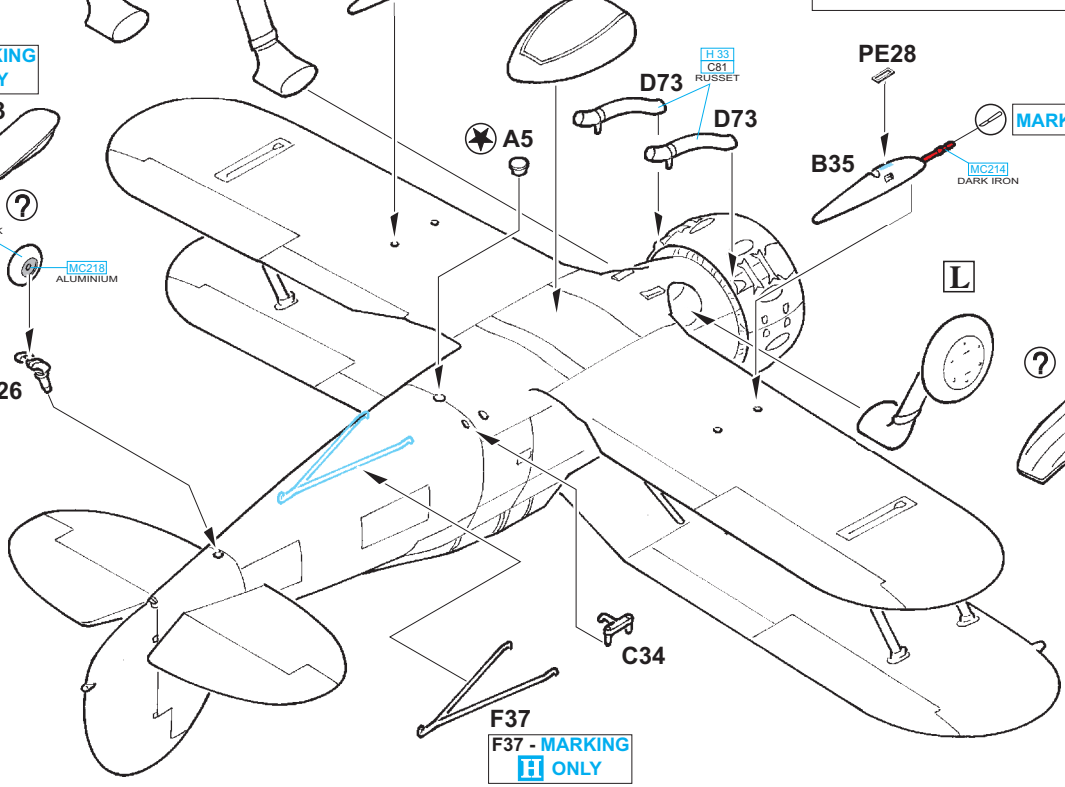
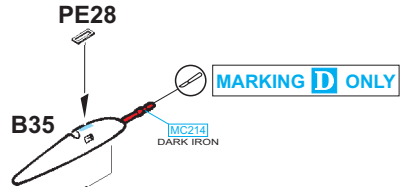
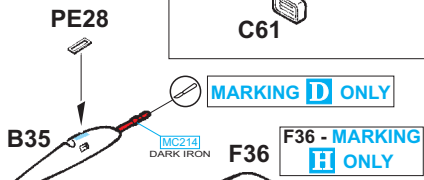
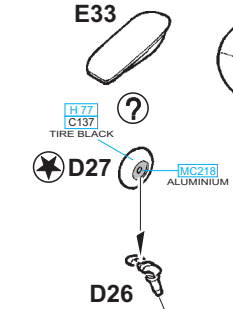

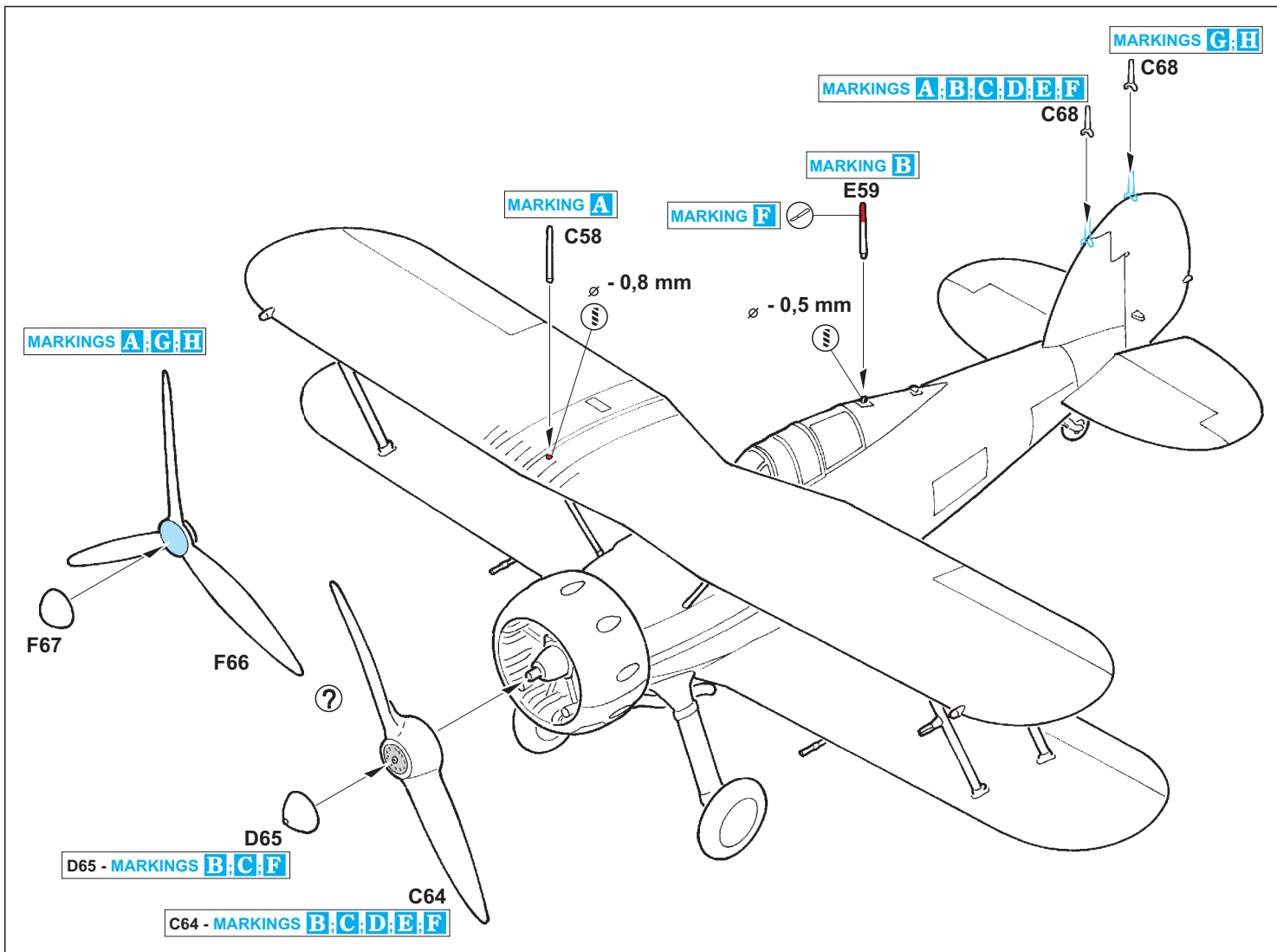

RIGGING DIAGRAM

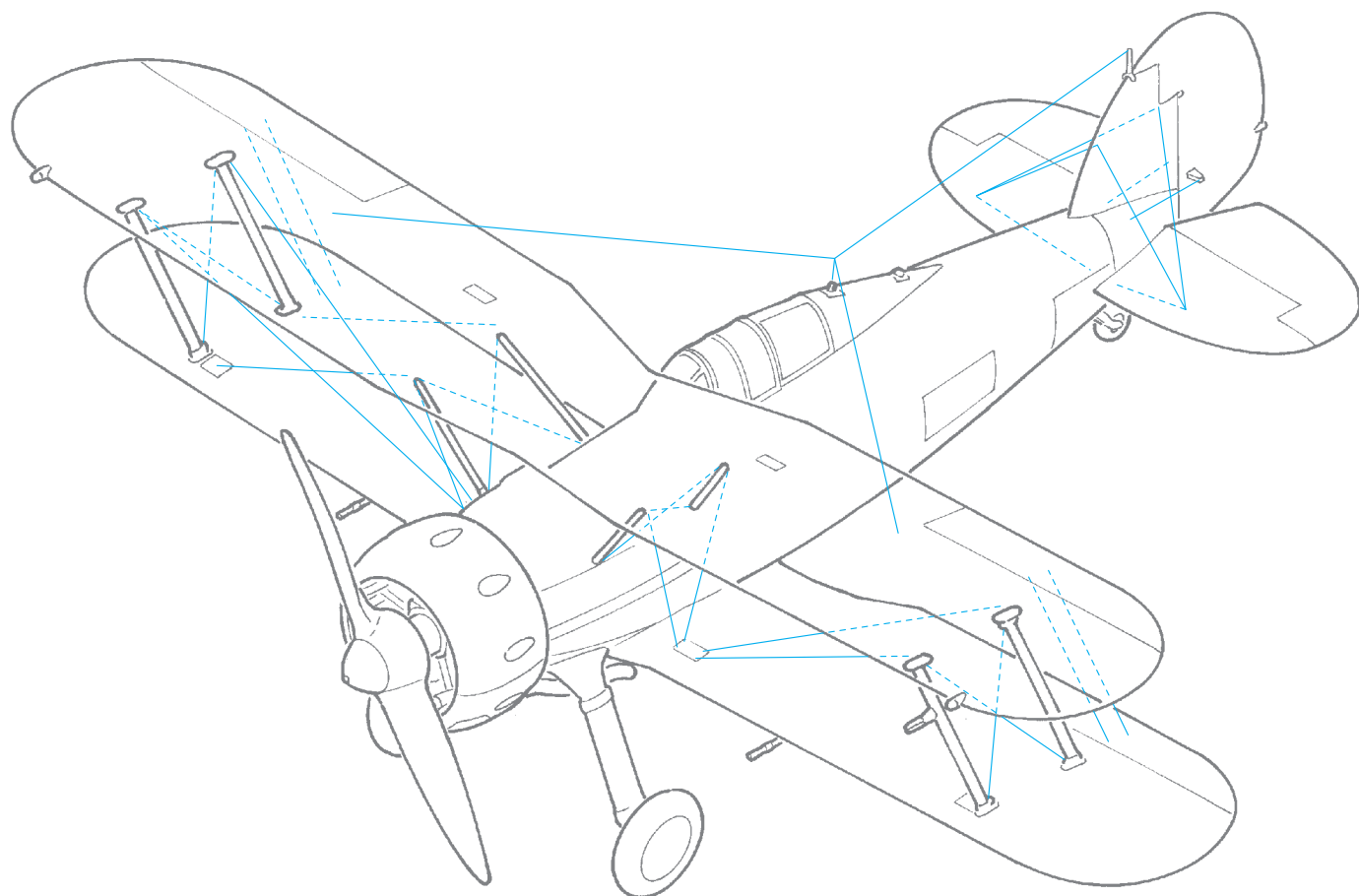

RIGGING DIAGRAM

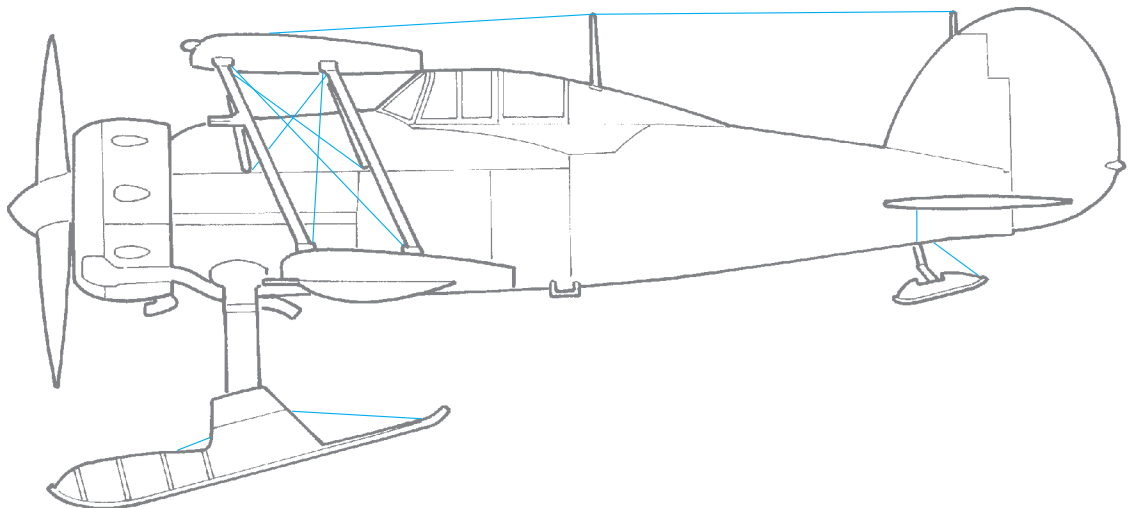
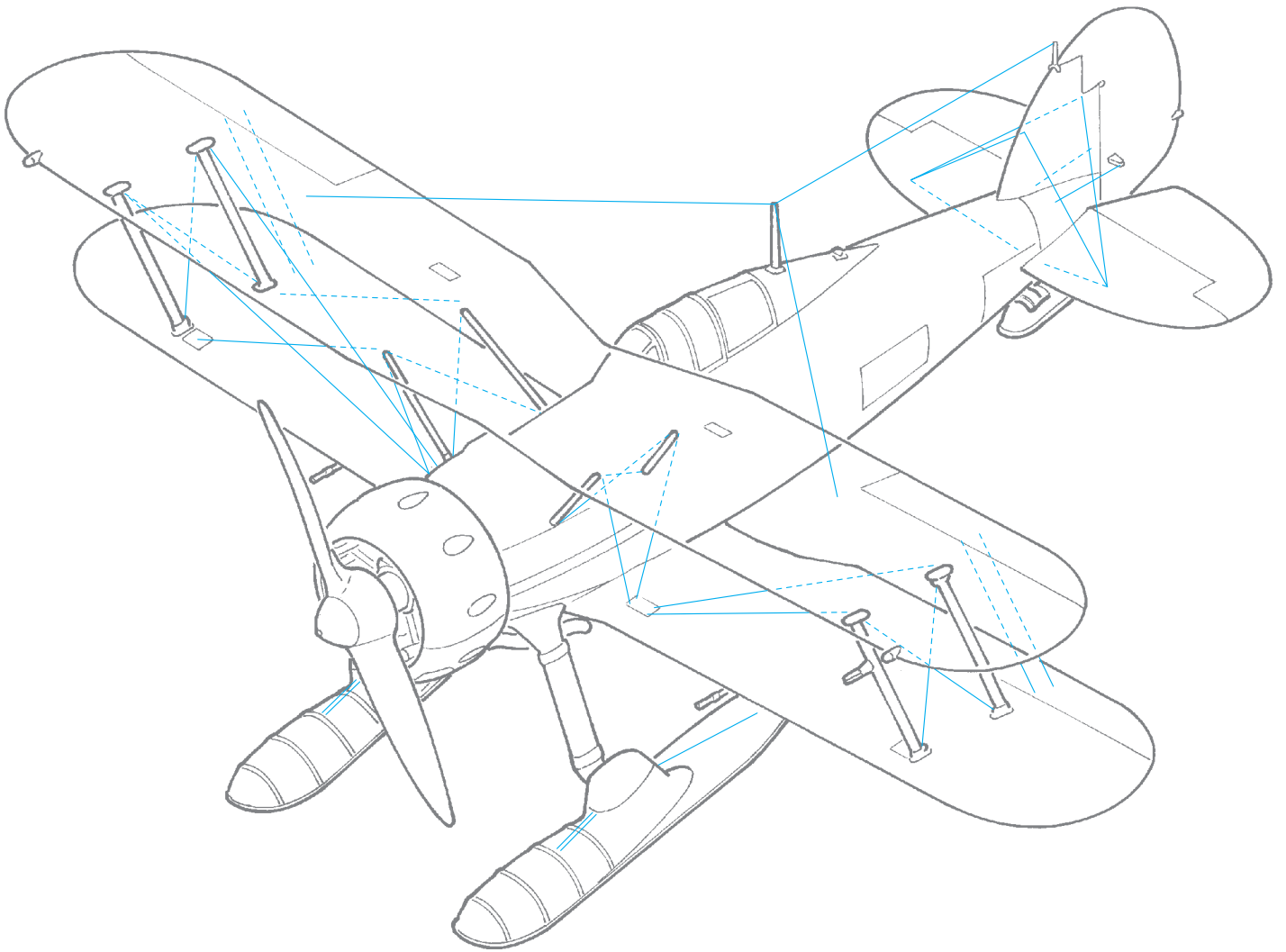

A Gladiator Mk.II, L9044, No. 3 Squadron RAAF, Maruba, Libya 1941

F/O Peter St. George Bruce Turnbull, DFC, flew this plane from Maruba and recorded one damaged Fiat G.50 with it (during this fight three of his four guns jammed). The plane sported the Shadow Compensating Scheme over the upper surfaces consisting of Dark Earth/Dark Green on the upper wing and upper part of fuselage and Light Earth/Light Green on the lower wing and sides of the fuselage. Undersides were painted black (port) and white (starboard). The plane had 'Sweet Sue' painted under the canopy (port side), surrounded by musical notes. Turnbull scored 12 victories during the war, four of them in a Hurricane Mk. I and five in a P-40 Tomahawk in Africa and the Middle East. He added three more Zeros to his tally after he moved to No. 75 Squadron and transitioned to a P-40 Kittyhawk in New Guinea. He died on August 7th when his plane hit trees while attacking ground targets.

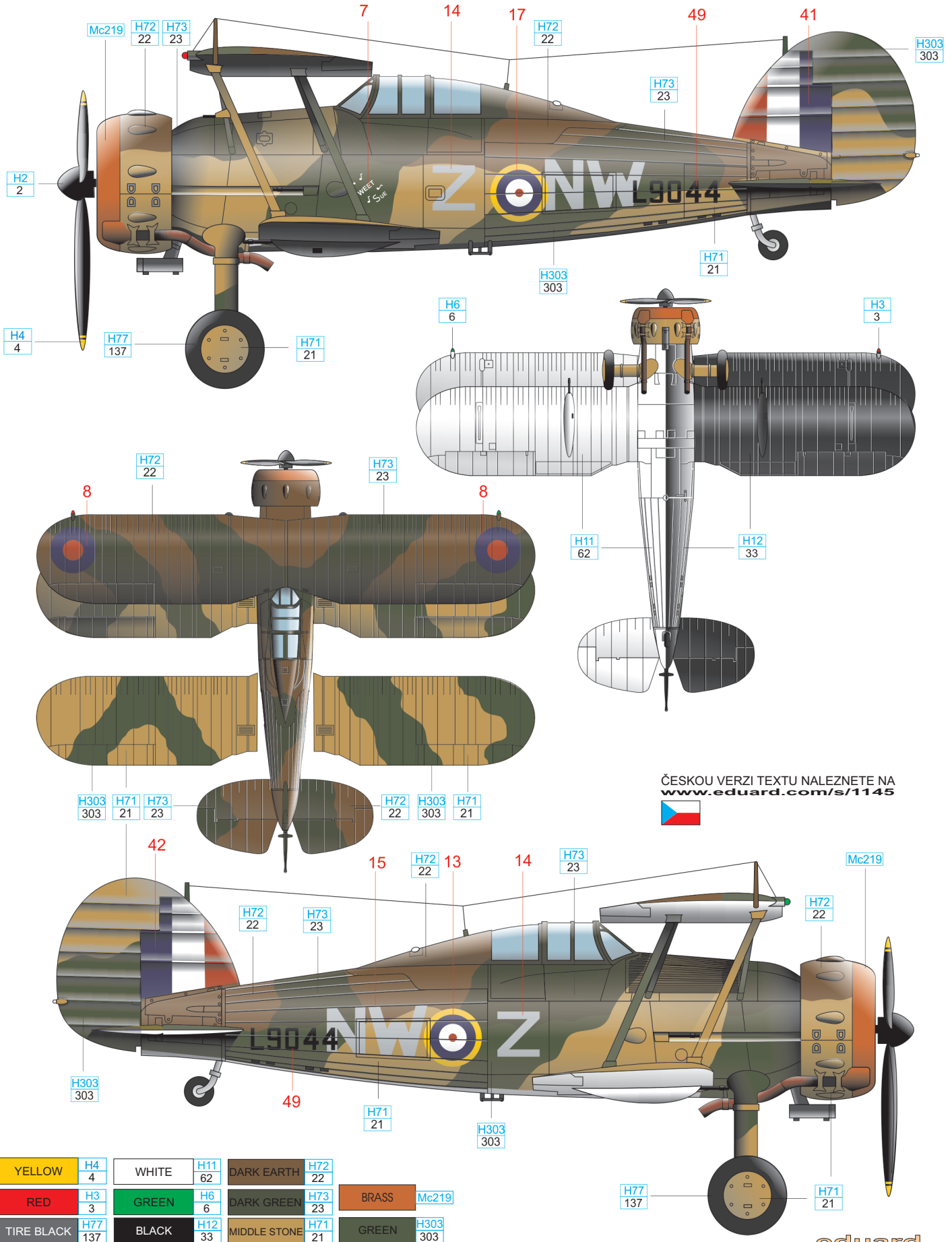

ČESKOU VERZI TEXTU NALEZNETE NA
www.eduard.com/s/1145



B Gloster Gladiator Mk.I (J8), 278, Flygflottilj 19, Finland, March 1940

One of a dozen planes of the Swedish volunteer Flygflottilj 19 unit sent to Finland in an attempt to help in the Winter War against Russia. The aircraft were marked with large yellow letters on the rudder (from A to J) and sported a modified camouflage scheme which was applied in two ways: The planes received from Britain in the silver scheme were painted with fields of dark grey, while those camouflaged green on top and grey underside received fields of aluminum, which consequently made them three colour schemes. This is the case of this plane. The blue Finnish swastikas were overpainted after the ceasefire agreement on March 13th, 1940. Prior to their return back to Sweden, the pilots and mechanics painted different personal symbols on both sides of their remaining planes. Also, a white skull was added to the fin. This aircraft reverted back to its original colour scheme after returning from Finland and served until June 30th, 1945, recording total of 699 flying hours. Currently, it is on display at the aviation museum in Linköping, but with a non original camouflage scheme applied during restoration.

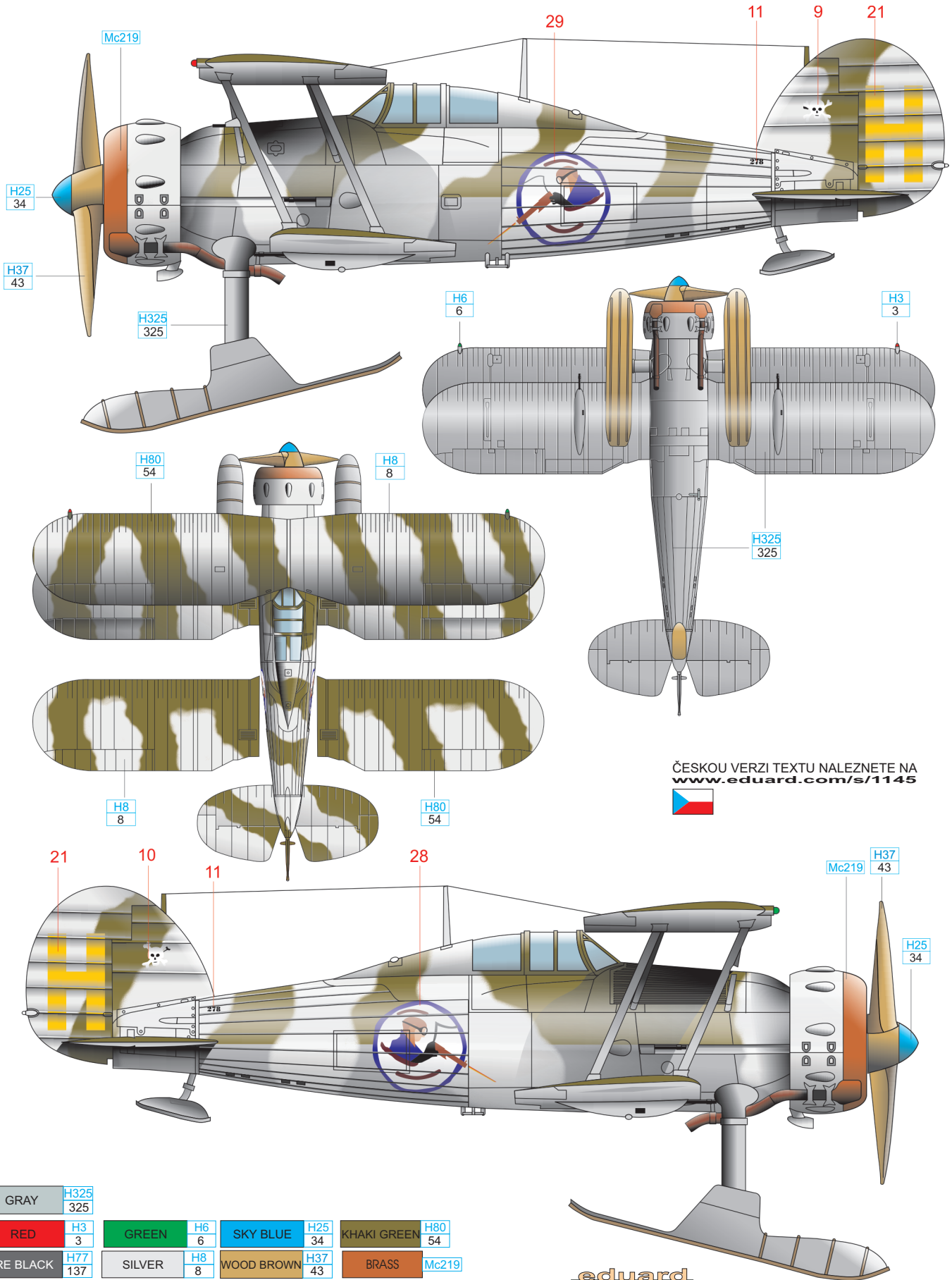

ČESKOU VERZI TEXTU NALEZNETE NA www.eduard.com/s/1145



| | | | | | |
|------------|-------------|--------|---------|------------|-----------|
| GRAY | H325 325 | | | | |
| RED | H3 3 | GREEN | H6 6 | SKY BLUE | H25 34 |
| TIRE BLACK | H77 137 | SILVER | H8 8 | WOOD BROWN | H37 43 |
| | | | | BRASS | Mc219 |
| | | | | | |
| | | | | | |

C Gladiator Mk.I, No. 123 Fighter Squadron, Spilve, Latvia 1938

Latvia ordered 26 Gladiators in 1937 and 1938. The planes were delivered dismantled on ships in three separate shipments. After assembly in Spilve, each plane was flight tested prior to acceptance by the Latvian Air Force. This airplane was assigned to the 123rd Fighter Squadron, which operated 13 aircraft. The other 13 planes were assigned to the 124th Fighter Squadron. There is a badge of the Latvian Air Force on both sides of the vertical fin. The rudder sports a picture of a woman, also on both sides. The plane was damaged in a landing accident in 1938. When the Red Army invaded Latvia, some of the Gladiators were confiscated, with red stars painted over the red swastikas.

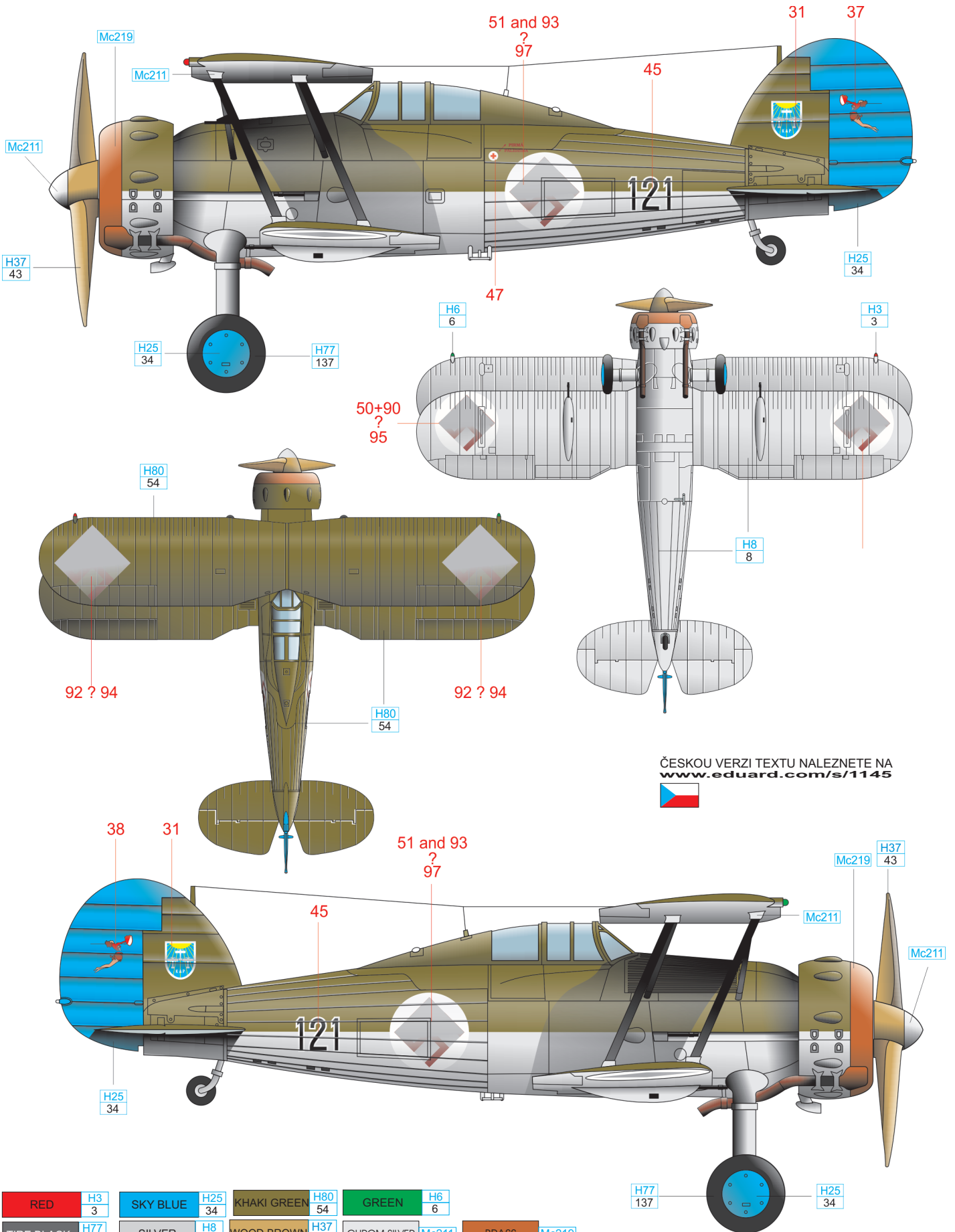

ČESKOU VERZI TEXTU NALEZNETE NA www.eduard.com/s/1145



| | | | | | | | |
|------------|------------|----------|-----------|-------------|-----------|--------------|---------|
| RED | H3 3 | SKY BLUE | H25 34 | KHAKI GREEN | H80 54 | GREEN | H6 6 |
| TIRE BLACK | H77 137 | SILVER | H8 8 | WOOD BROWN | H37 43 | CHROM SILVER | Mc211 |
| | | | | | | BRASS | Mc219 |

D Gladiator Mk. I K7985, No. 73 Squadron RAF, Church Fenton, England, September 1937

Personal plane of P/O E. J. 'Cobber' Kain, who became the first British ace of World War II. He was killed on June 5th 1940 in a crash. The plane operated for some time without armament presumably because of a supply shortage. The markings are typical for the period, with all surfaces in silver, supplemented with colourful squadron insignia on the fuselage and on top of the upper wing, in this case in a striking yellow-blue combination.

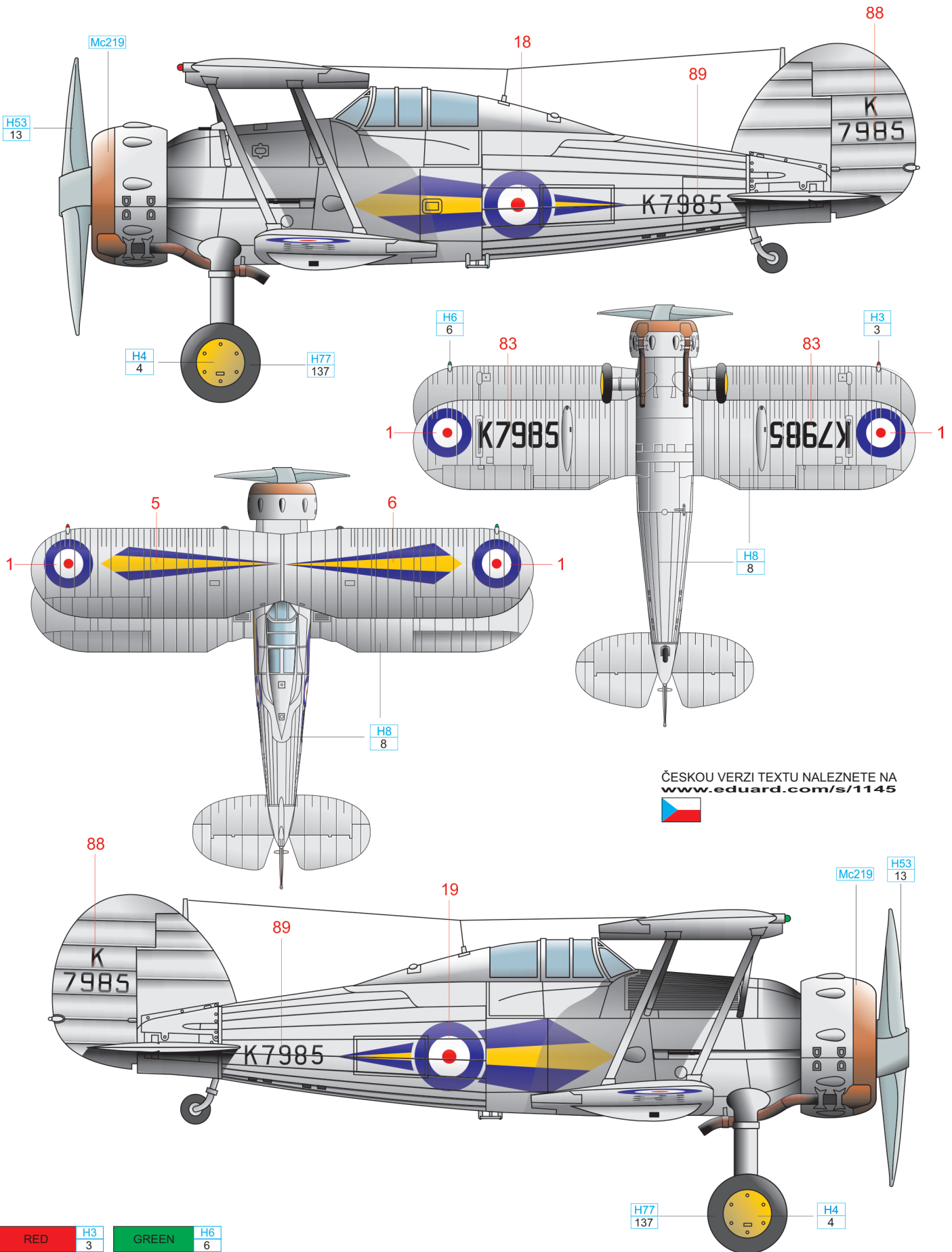

ČESKOU VERZI TEXTU NALEZNETE NA
www.eduard.com/s/1145



| | | | |
|--------------|-----------|------------|------------|
| RED | H3 3 | GREEN | H6 6 |
| NEUTRAL GRAY | H53 13 | TIRE BLACK | H77 137 |
| SILVER | H8 8 | YELLOW | H4 4 |
| | | BRASS | Mc219 |

E Gladiator Mk. I, K7974, No. 87 Squadron, Shoreham, England, 1938

This plane sported the standard silver scheme with squadron emblem consisting of a green wave over a black straight line, the marking of No. 87 Squadron. Interestingly, the port side of the vertical fin has been painted with the badge of No. 601 Squadron, although the unit never flew Gladiators. The starboard side of the vertical fin bears a rendition of Popeye the Sailor. The plane was delivered to No. 122 Squadron in June 1939 and on the 1st of August 1940, P/O Green shot down an Italian Caproni Ca.133 flying it. However, in the same year, on December 12th, the airplane was lost in an accident, while attempting to take off from Port Sudan airfield.

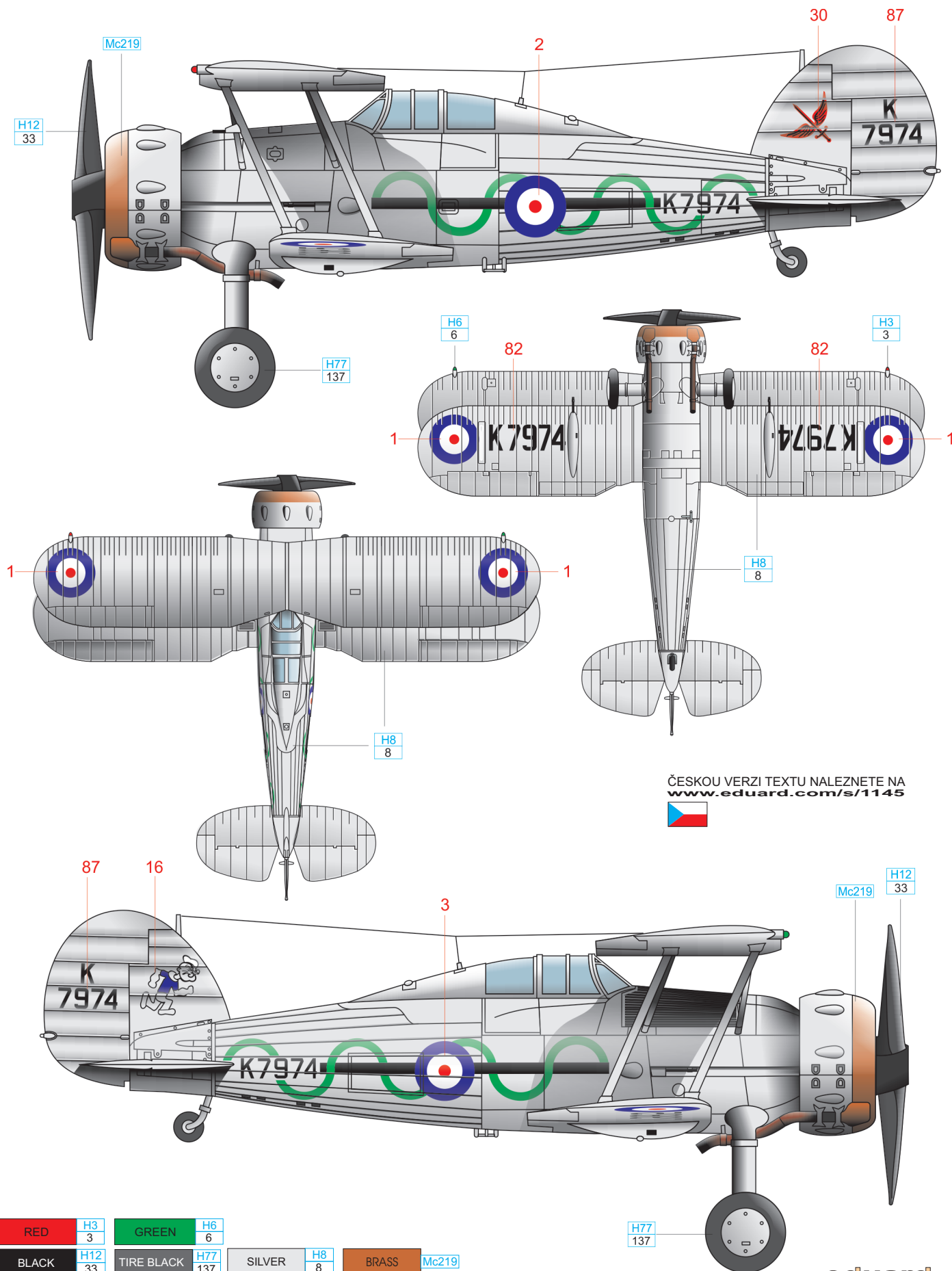

ČESKOU VERZI TEXTU NALEZNETE NA
www.eduard.com/s/1145



| | | | | | | | |
|-------|-----------|------------|------------|--------|---------|-------|-------|
| RED | H3 3 | GREEN | H6 6 | SILVER | H8 8 | BRASS | Mc219 |
| BLACK | H12 33 | TIRE BLACK | H77 137 | | | | |

F Gladiator Mk.I, 1^{er} Escadrille du 1^{er} Groupe du 2^{ème} Regiment Aeronautique, Schaffen, Belgium 1939

Belgium ordered and obtained 22 Gladiators during 1937 and 1938. Although all were Mk.I standards, some of the last ones were given a three blade Fairey Reed propeller. This aircraft had the standard two blade Watts propeller. Shortly after delivery, some technical and maintenance information was painted on both sides of the rudder as a common practice of the Belgian Air Force. The fuselage obtained a stylized depiction of a comet, after the name of the unit, 'Comete'. Some 15 planes were in operational condition just prior to the German invasion, and Belgian pilots used them to attempt to stop or slow the enemy advance. However, all the planes were lost on May 11th, 1940, when four of six were shot down during a mission covering Fairey Battle bombers. The remaining aircraft were destroyed on the ground during the bombing of Beauvechain.

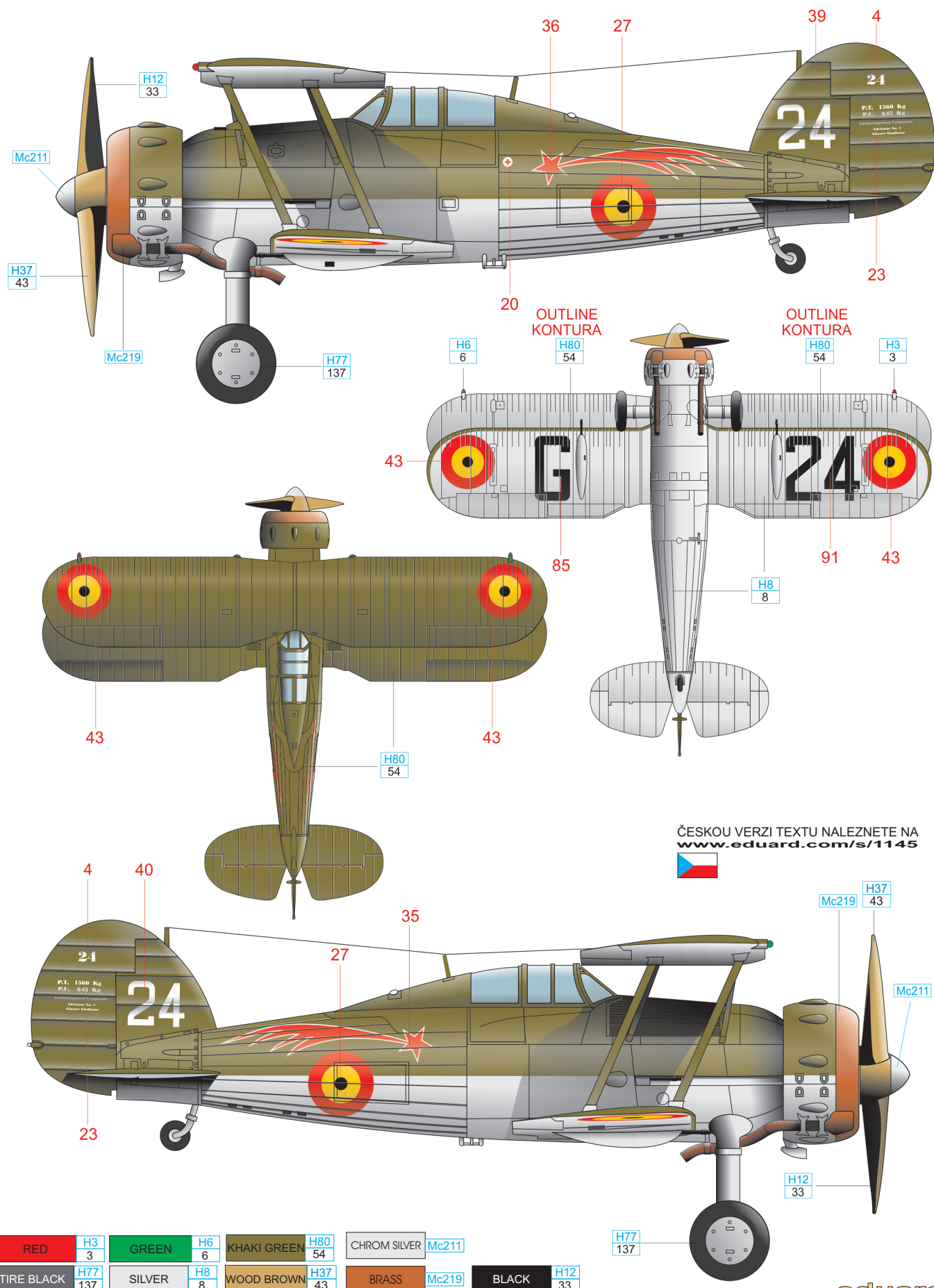

ČESKOU VERZI TEXTU NALEZNETE NA www.eduard.com/s/1145



| | | | | | | | |
|------------|------------|--------|---------|-------------|-----------|--------------|-----------|
| RED | H3 3 | GREEN | H6 6 | KHAKI GREEN | H80 54 | CHROM SILVER | Mc211 |
| TIRE BLACK | H77 137 | SILVER | H8 8 | WOOD BROWN | H37 43 | BRASS | Mc219 |
| | | | | | | BLACK | H12 33 |

G Gladiator Mk.II, N2308, No. 615 Squadron RAF 'County of Surrey', Merville, France 1939

Two Squadrons of the BEF (British Expeditionary Force) were flying Gladiators at the time of the invasion of France, Nos. 607 and 615. Just as both squadrons were to re-equip with Hurricanes, the German Blitzkrieg began, effectively interrupting the process. According to the operational record book of No. 607 Squadron (records of No. 615 have been lost), pilots of the two units destroyed some 72 enemy aircraft and, because of the relatively small number of sorties flown by Hurricanes, it is likely that some of the victories belonged to Gladiator pilots. Other sources credit this plane with sole aerial victory achieved by Gladiator in France, as F/L James Sanders damaged He 111 on December 29th, 1939. This Gladiator was one of the few which made it back to Britain. The plane sported the Shadow Compensating Scheme over the upper surfaces consisting of Dark Earth/Dark Green on the upper wing and upper part of fuselage and Light Earth/Light Green on the lower wing and sides of the fuselage. Undersides were painted black (port) and white (starboard). The serial number was overpainted, probably with some camouflage colours. An area at the bottom of the port side roundel seems to be repaired, using unidentified dark colour, perhaps dull red. Additionally, the area under the canopy seems to be repaired, as the upper and aft vertical line of the Light Earth field with the KW code is straight.

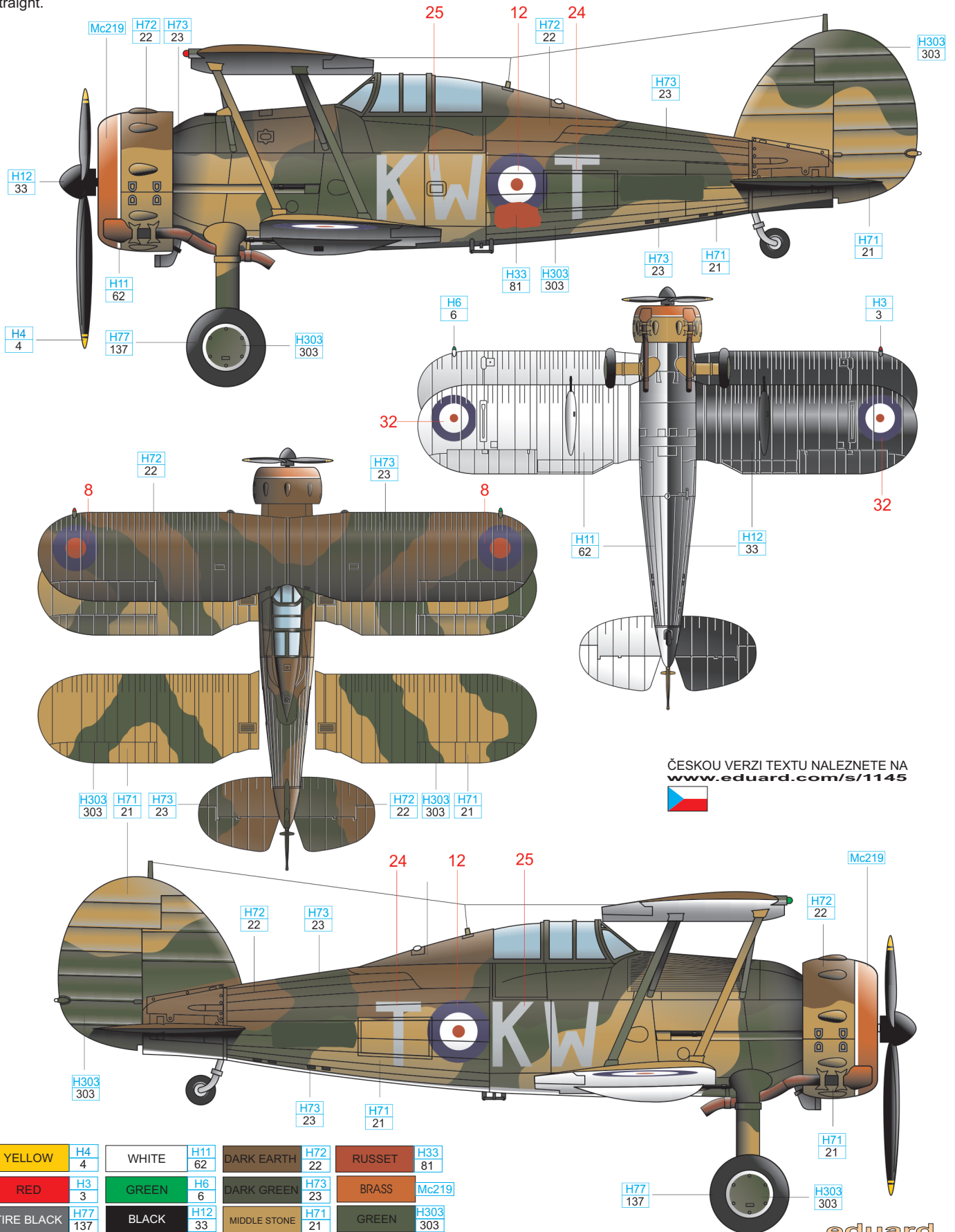

ČESKOU VERZI TEXTU NALEZNETE NA www.eduard.com/s/1145



| | | | | | | | |
|------------|------------|-------|-----------|--------------|-----------|--------|-------------|
| YELLOW | H4 4 | WHITE | H11 62 | DARK EARTH | H72 22 | RUSSET | H33 81 |
| RED | H3 3 | GREEN | H6 6 | DARK GREEN | H73 23 | BRASS | Mc219 |
| TIRE BLACK | H77 137 | BLACK | H12 33 | MIDDLE STONE | H71 21 | GREEN | H303 303 |

H Sea Gladiator Mk.II, N5517, 813 Naval Air Squadron, HMS Eagle, July 1940

Cdr Charles Lindsay Keighly-Peach, DSO, operated this Sea Gladiator from the deck of HMS Eagle in the Mediterranean Sea. He managed to shoot down 3.5 Italian bombers flying the N5517. The plane was later assigned to No. 805 Squadron NAS and destroyed during an emergency landing attempt on May 15th, 1941. The upper wing and upper part of the fuselage were painted Extra Dark Sea Grey and Dark Slate Grey, upper side of the lower wing in Dark Sea Grey and Light Slate Grey. Under surfaces, lower sides of fuselage and vertical stabilizer with rudder were in Sky Grey.

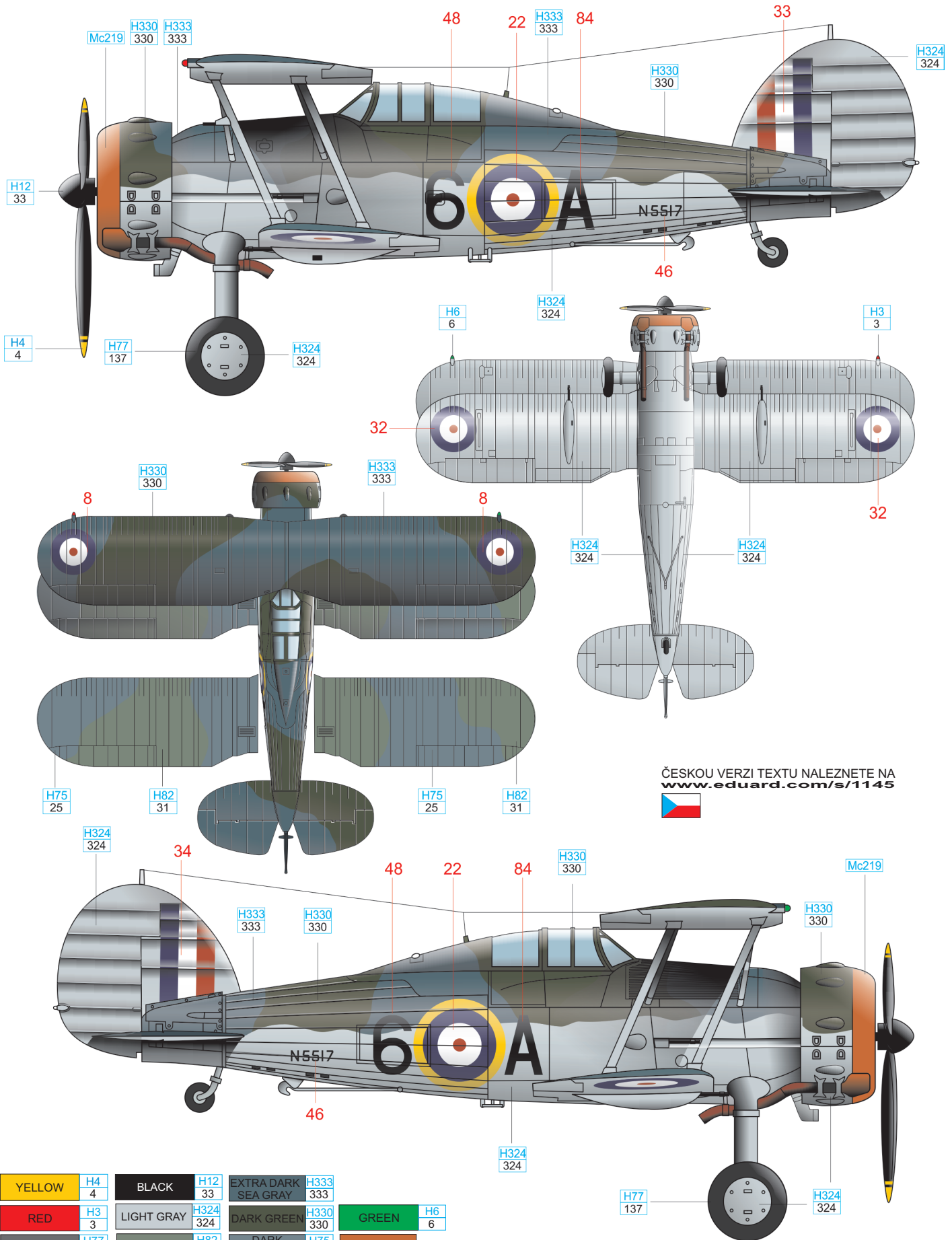

ČESKOU VERZI TEXTU NALEZNETE NA
www.eduard.com/s/1145



| | | | | | |
|------------|------------|------------|-------------|---------------------|-------------|
| YELLOW | H4 4 | BLACK | H12 33 | EXTRA DARK SEA GRAY | H333 333 |
| RED | H3 3 | LIGHT GRAY | H324 324 | DARK GREEN | H330 330 |
| TIRE BLACK | H77 137 | DARK GRAY | H82 31 | DARK SEA GRAY | H75 25 |
| | | | | GREEN | H6 6 |
| | | | | BRASS | Mc219 |

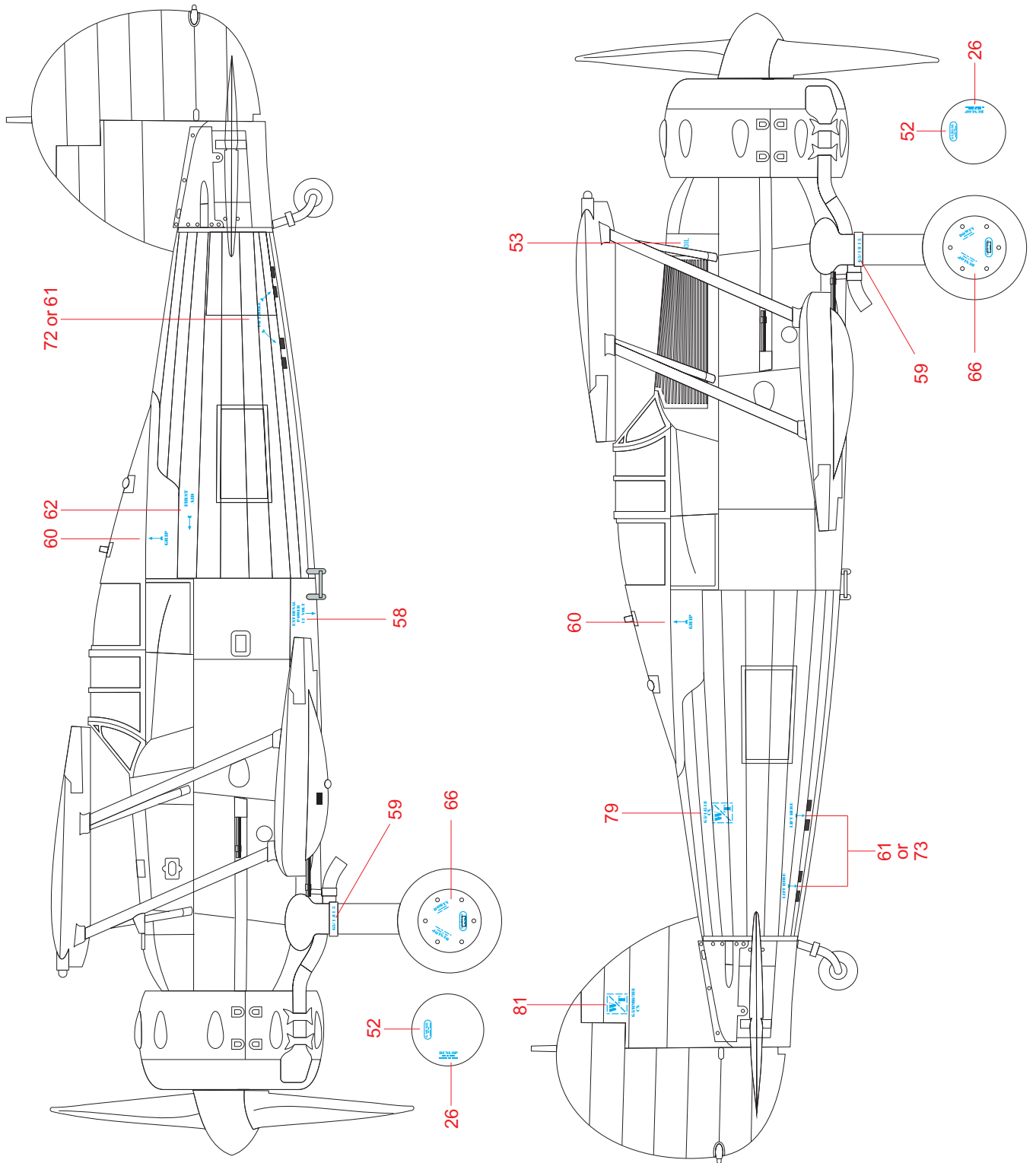

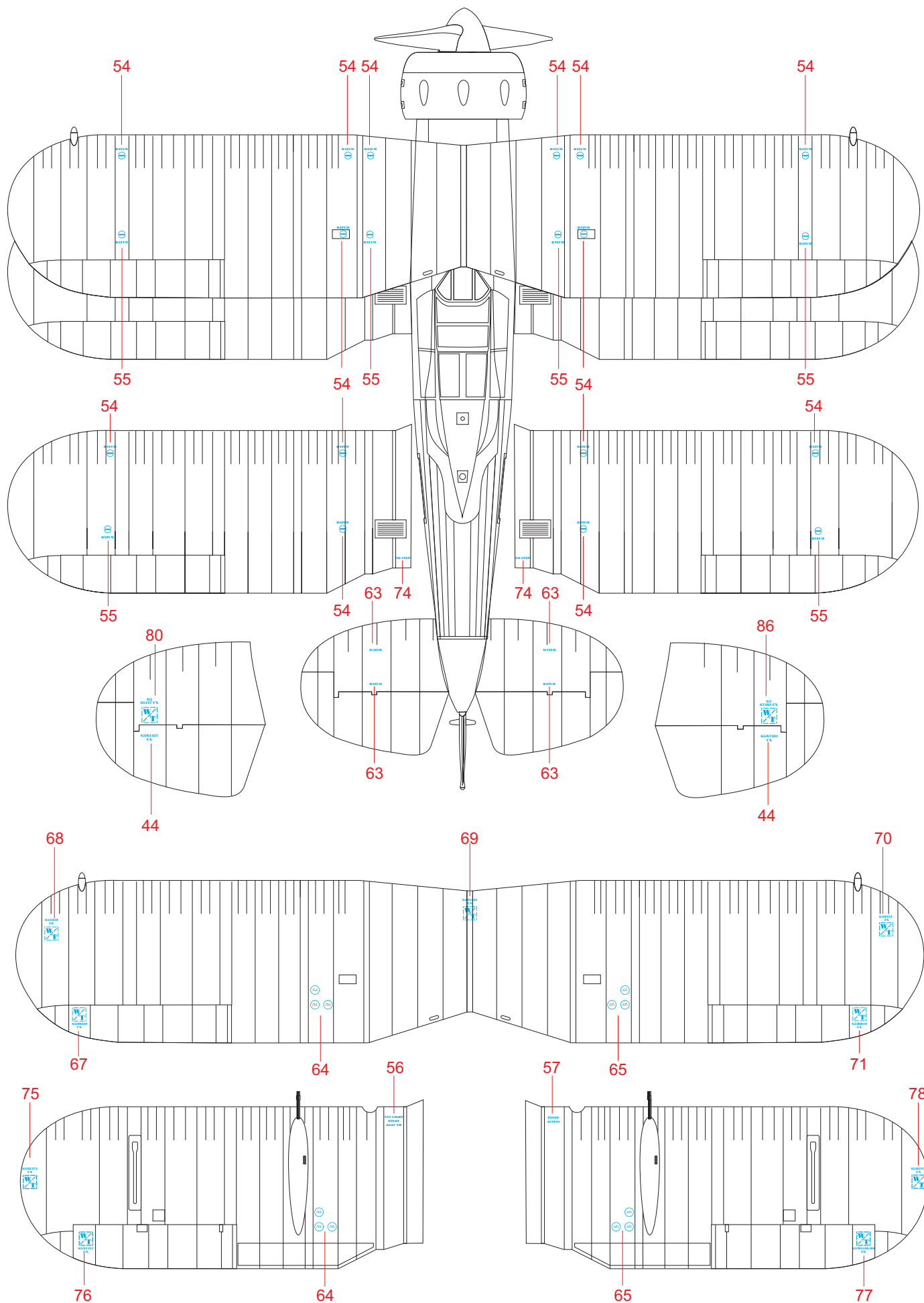

GLADIATOR

PHOTO-ETCHED SET

Cat. No. 48862
 Gladiator upgrade set

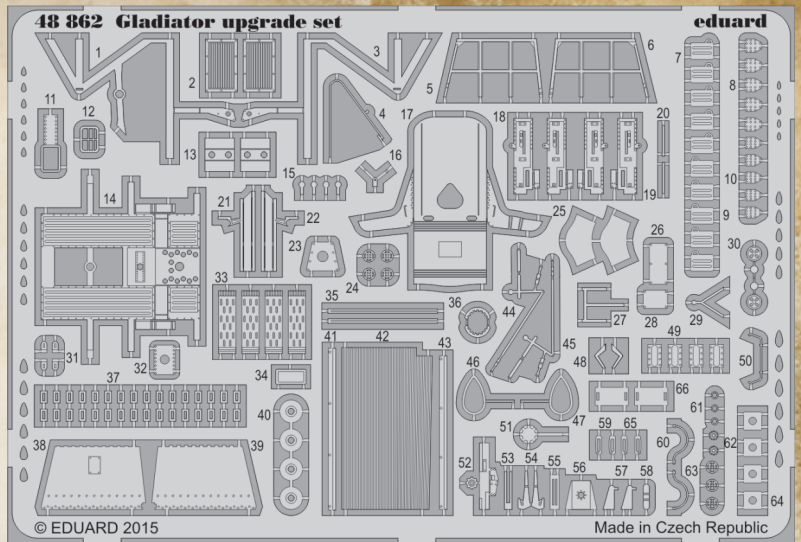

RECOMMENDED KITS:

Spitfire Mk.IXc late version **ProfiPACK** edition

1/48 scale

Cat. No. 8281

eduard **Spitfire Mk.IXc late version**

WEEKEND edition 1/48

Cat. No. 84136

Spitfire Mk.IXc **SUPER44**

1/144 scale **Dual Combo** **eduard**

Cat. No. 4429

WWW.EDUARD.COM