

84144
1:48

Bf 110E

eduard
WEEKEND

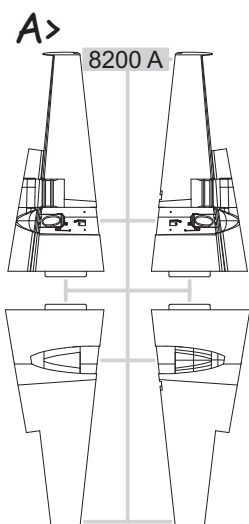

B> PLASTIC PARTS

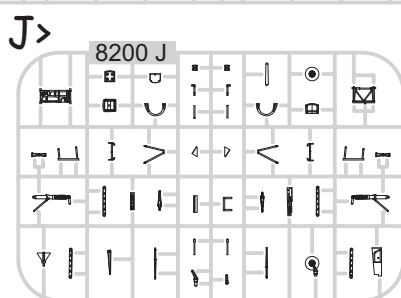
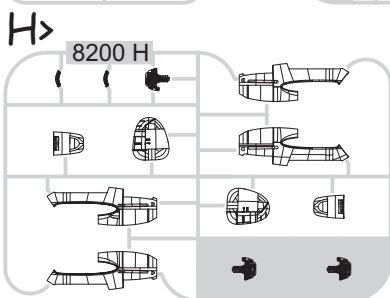
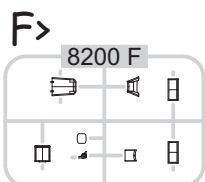
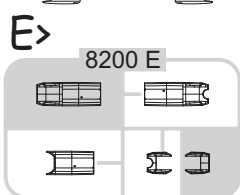
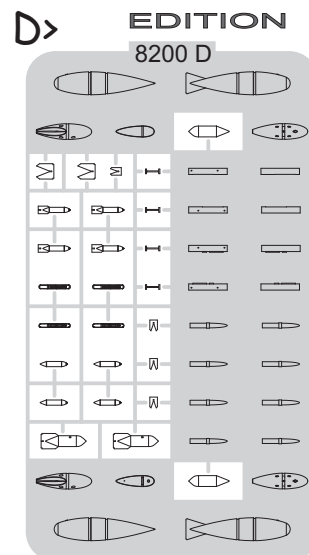
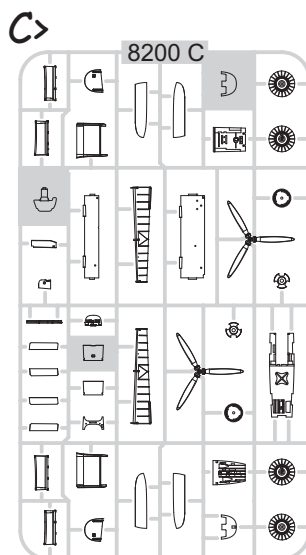
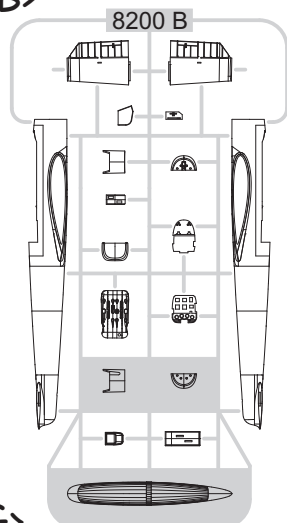

Mr.COLOR	
C3	RED
C4	YELLOW
C5	BLUE
C7	BROWN
C18	RLM 70
C33	FLAT BLACK
C36	RLM 74
C37	RLM 75
C41	RED BROWN
C60	RLM 02
C62	WHITE
C116	RLM 66
C117	RLM 76
C137	TIRE BLACK

HOBBY COLOR	
H80	KHAKI GREEN
H344	RUST

Mr. METAL COLOR	
MC214	DARK IRON
MC219	BRASS

ATTENTION * UPOZORNĚNÍ * ACHTUNG * ATTENTION

- (GB)** Carefully read instruction sheet before assembling. When you use glue or paint, do not use near open flame and use in well ventilated room. Keep out of reach of small children. Children must not be allowed to suck any part, or pull vinyl bag over the head.
- (CZ)** Před započatím stavby si pečlivě prostudujte stavební návod. Při používání barev a lepidel pracujte v dobře větrané místnosti. Lepidla ani barvy nepoužívejte v blízkosti otevřeného ohně. Model není určen malým dětem, mohlo by dojít k požití drobných dílů.
- (D)** Von dem Zusammensetzen die Bauanleitung gut durchlesen. Kleber und Farbe nicht nahe von offenem Feuer verwenden und das Fenster von Zeit zu Zeit Belüftung öffnen. Bausatz von kleinen Kindern fernhalten. Verhüten Sie, daß Kinder irgendwelche Bauteile in den Mund nehmen oder Plastiktüten über den Kopf ziehen.
- (F)** Lire soigneusement la fiche d'instructions avant d'assembler. Ne pas utiliser de colle ou de peinture à proximité d'une flamme nue, et aérer la pièce de temps en temps. Garder hors de portée des enfants en bas âge. Ne pas laisser les enfants mettre en bouche ou sucer les pièces, ou passer un sachet vinyl sur la tête.

INSTRUCTION SIGNS * INSTR. SYMBOLY * INSTRUKTION SINNBILDEN * SYMBOLES

- (?)** OPTIONAL
FACULTATIF
NACH BELIEBEN
VOLBA
- (↶)** BEND
PLIER SIL VOUS PLAÎT
BITTE BIEGEN
OHNOUT
- (⊘)** OPEN HOLE
FAIRE UN TROU
OFFNEN
VYVRTAT OTVOR
- (↔)** SYMETRICAL ASSEMBLY
MONTAGE SYMÉTRIQUE
SYMMETRISCHE AUFBAU
SYMETRICKÁ MONTÁŽ
- (✂)** NOTCH
L INCISION
DER EINSCHNITT
ZÁŘEZ
- (✂)** REMOVE
RETIRER
ENTFERNEN
ODŘÍZNOUT

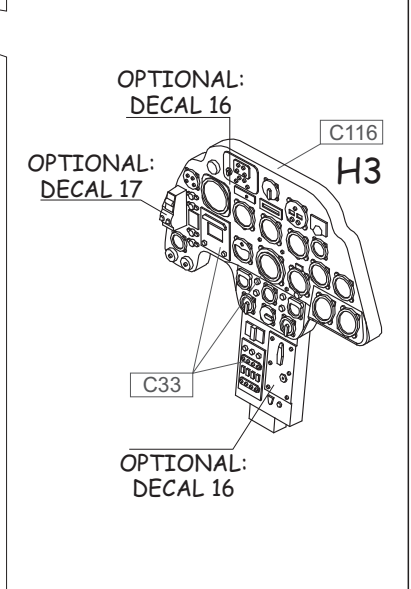
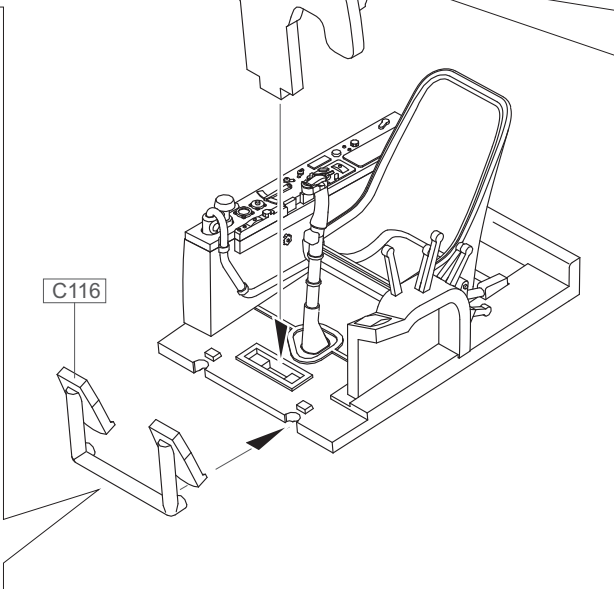
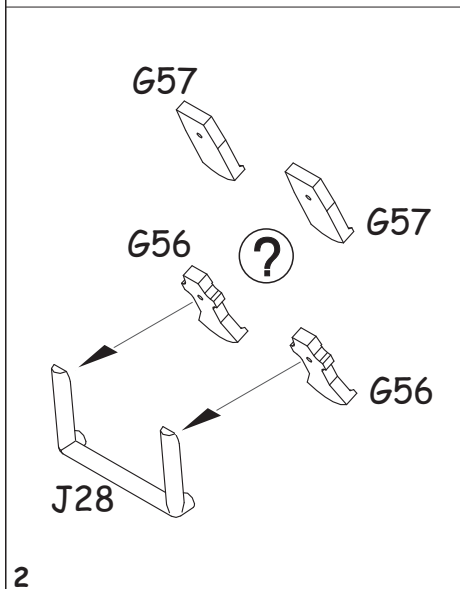
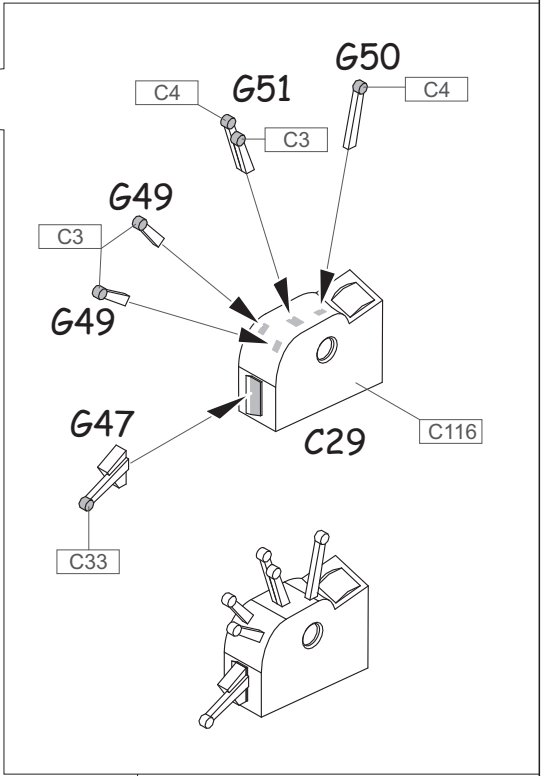
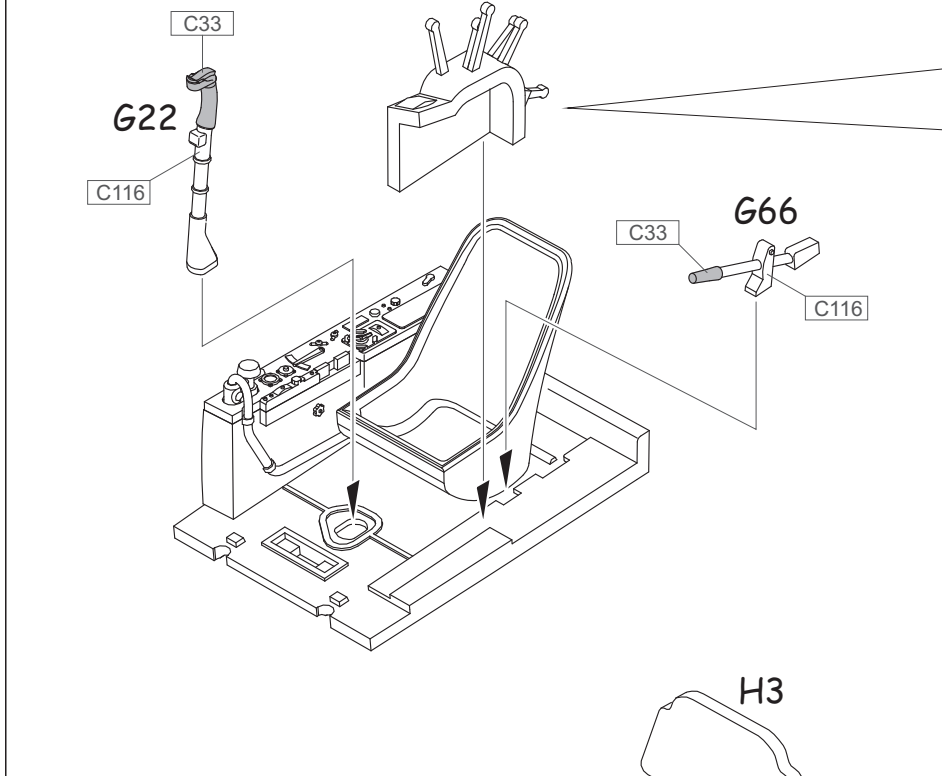
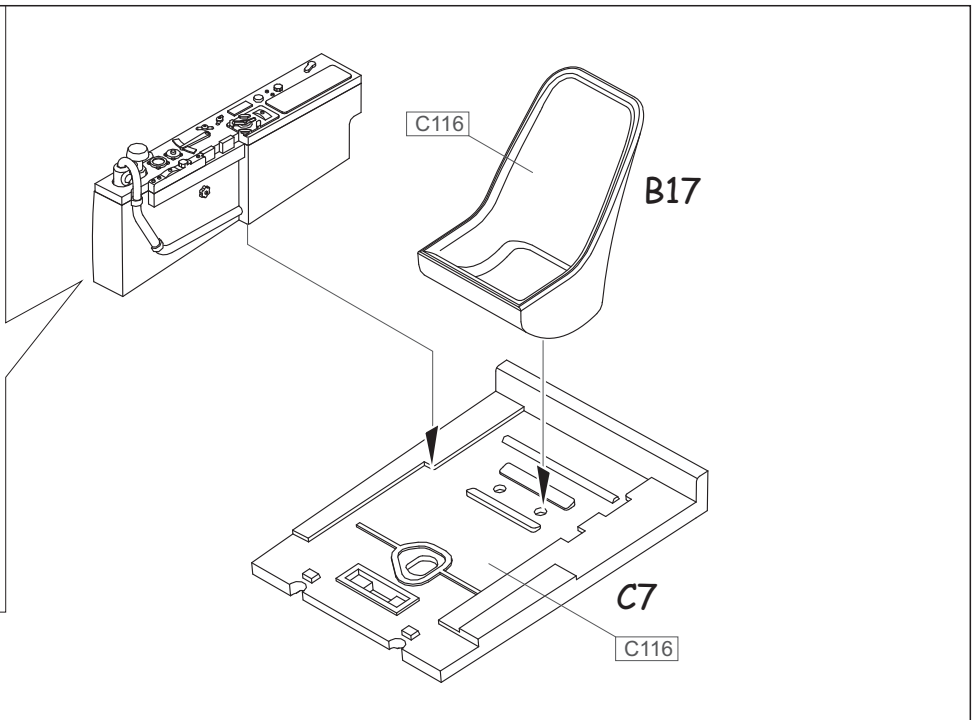
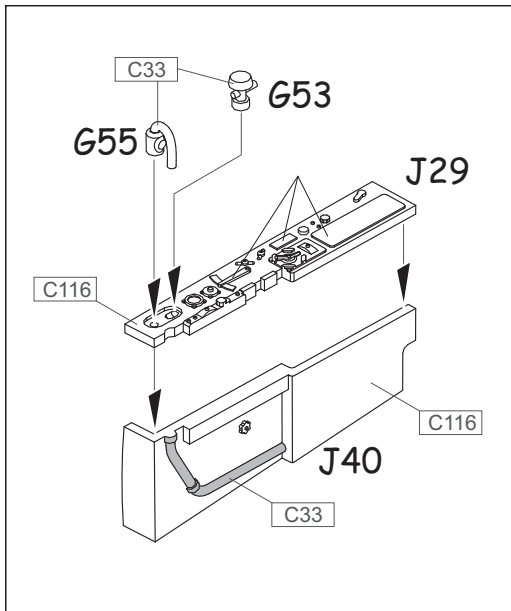

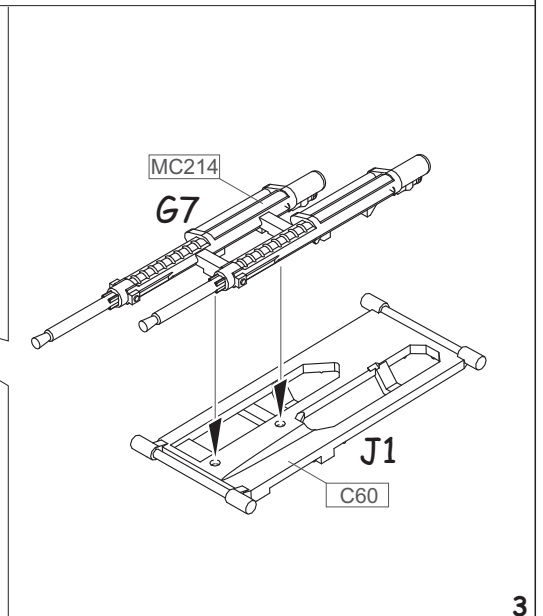
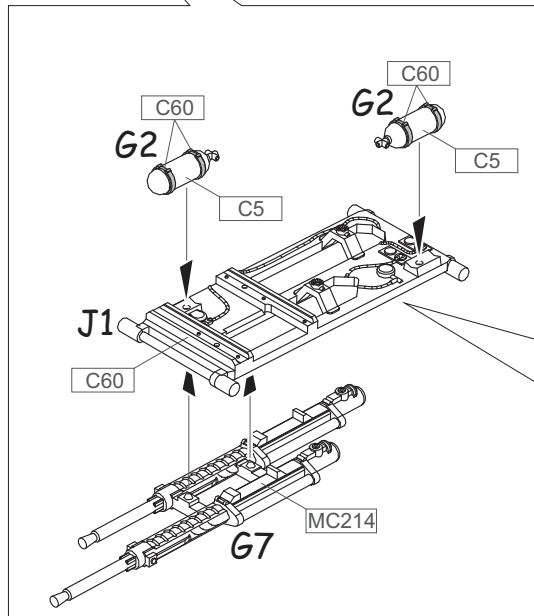
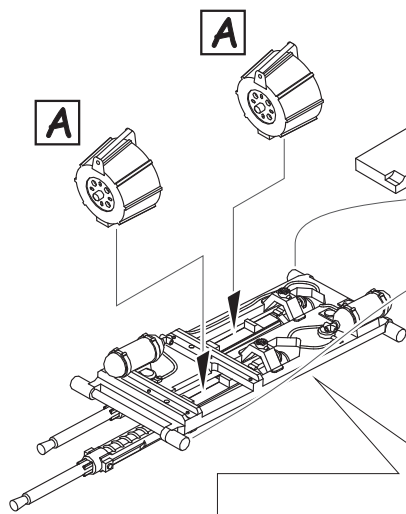
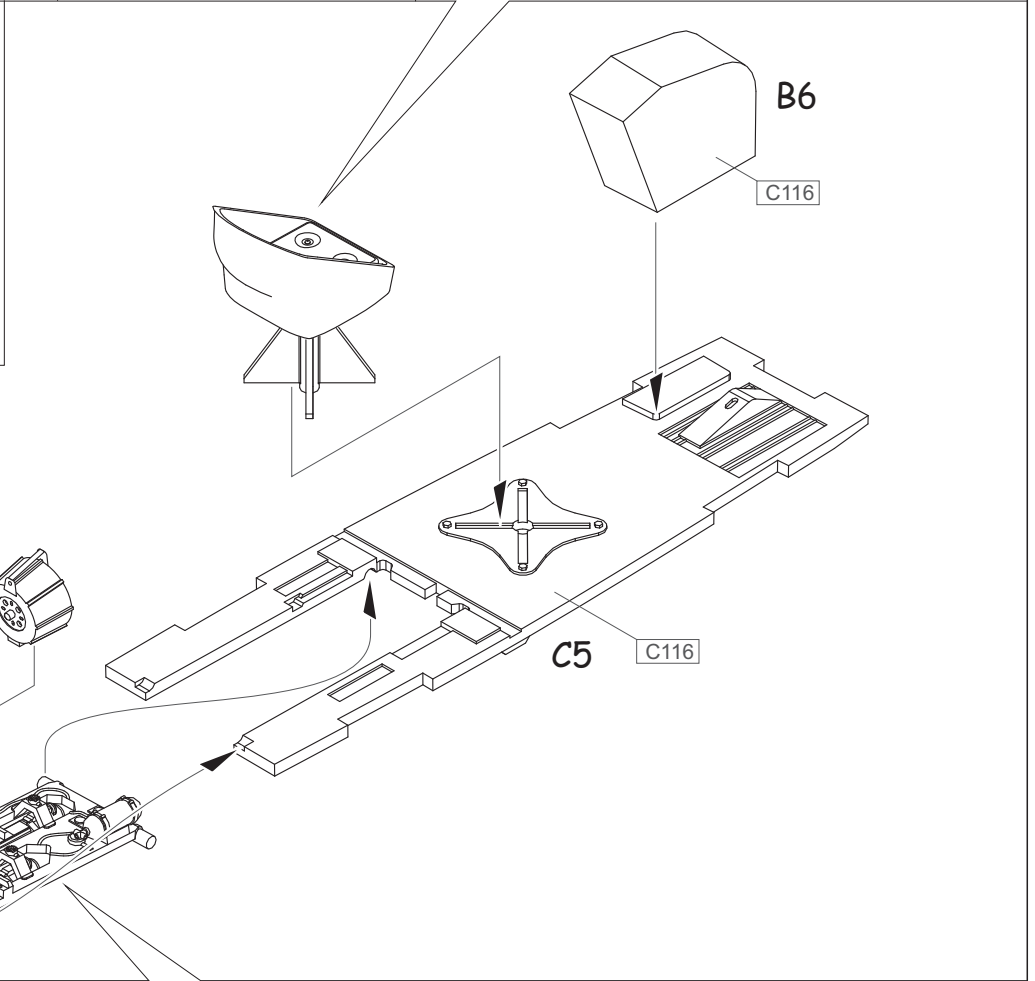
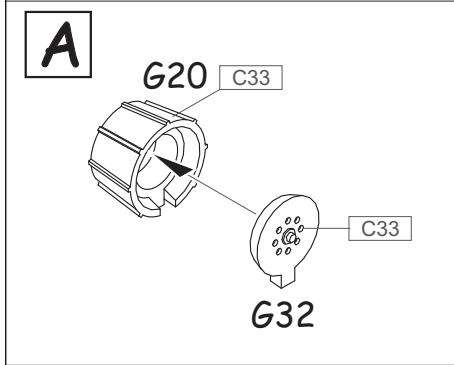
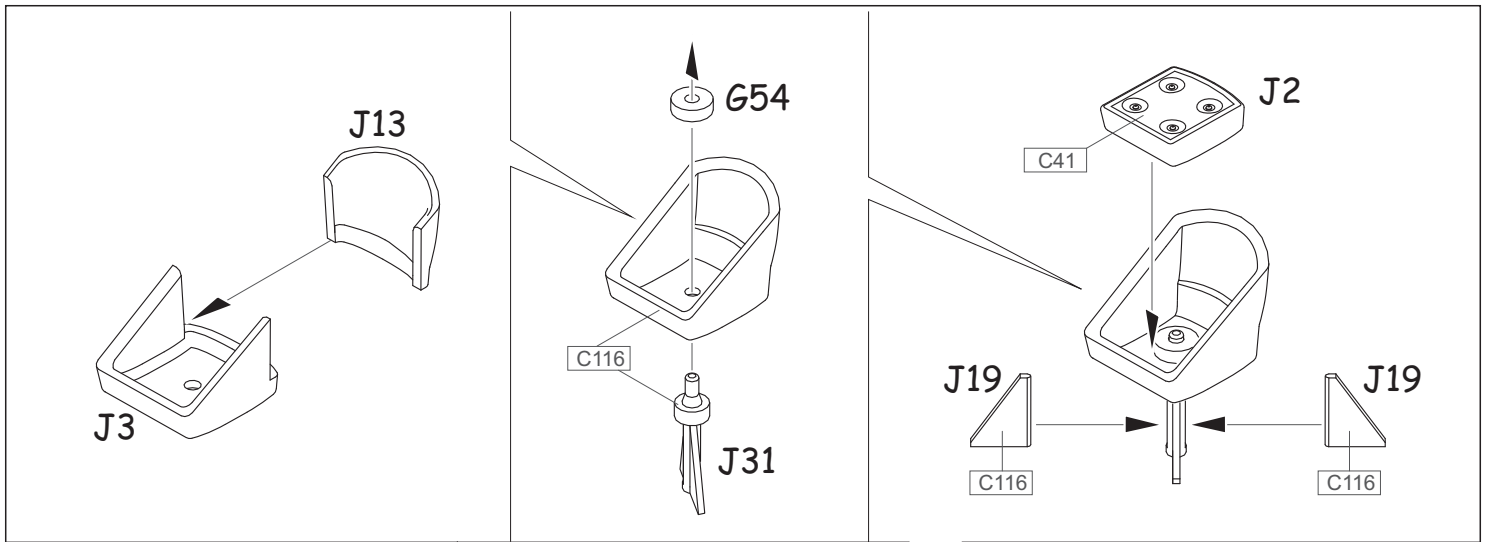

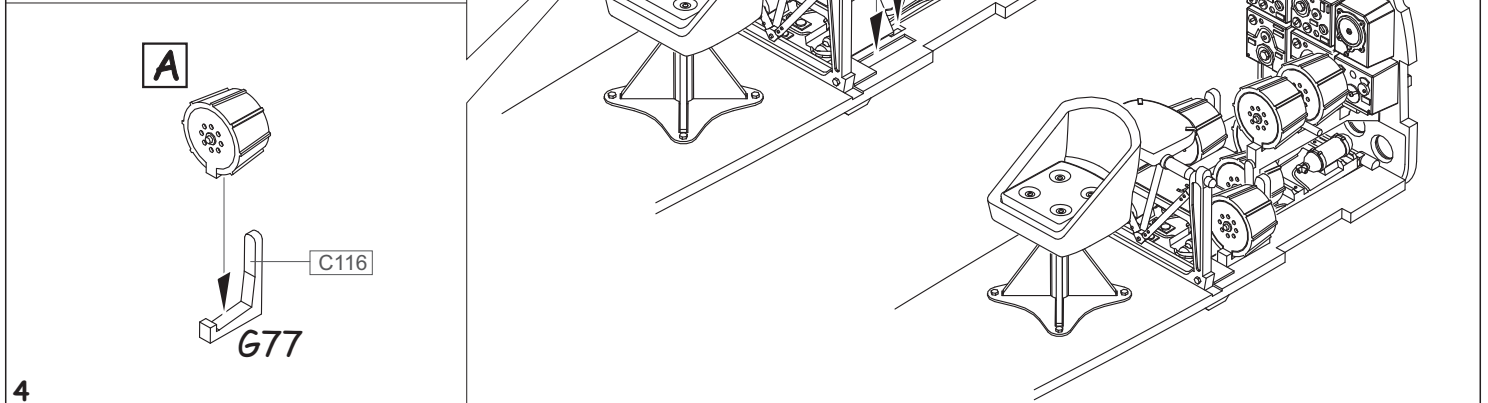
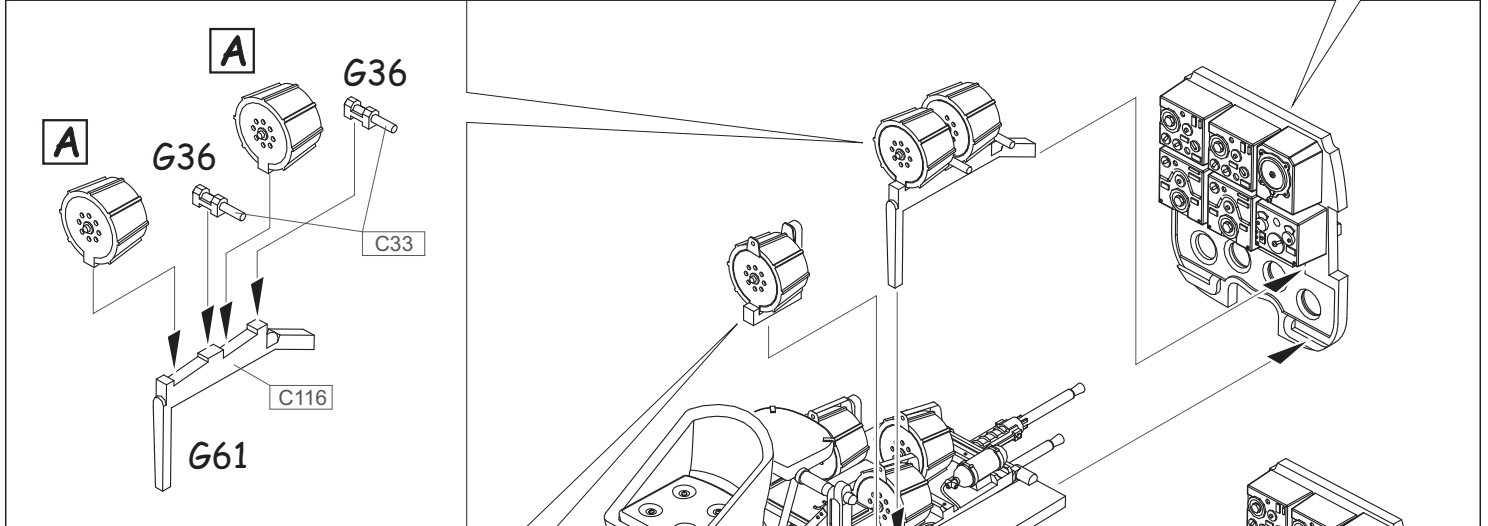
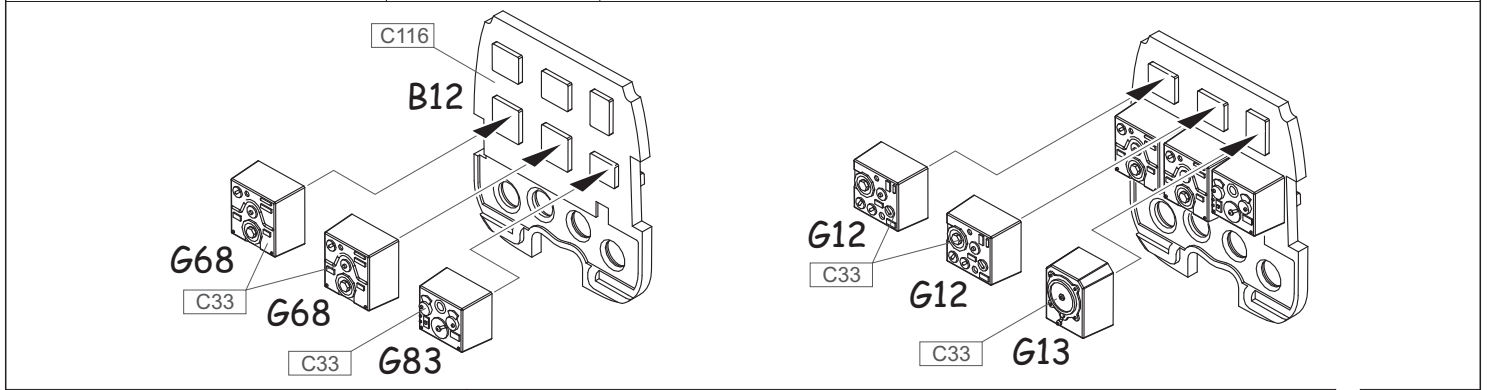
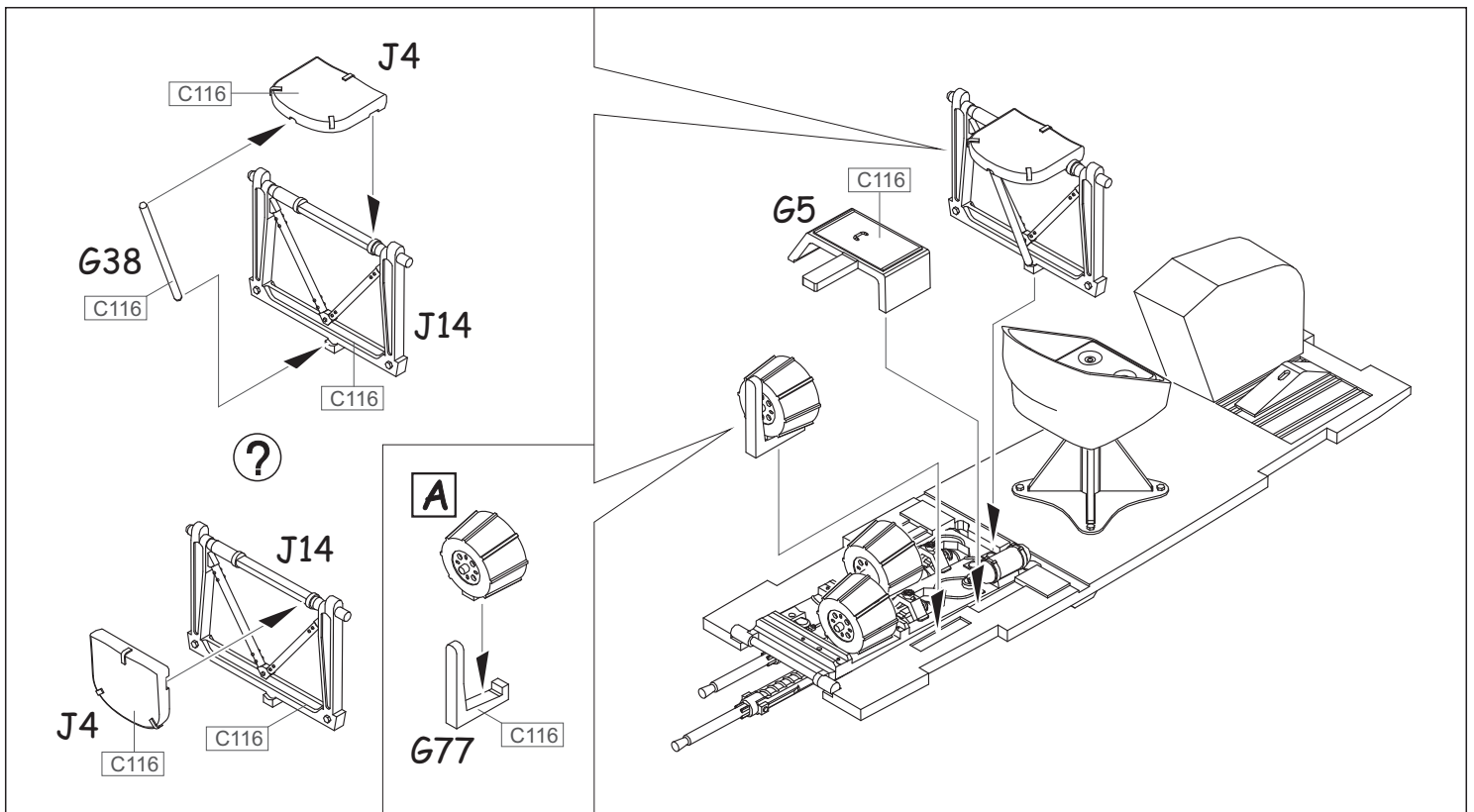

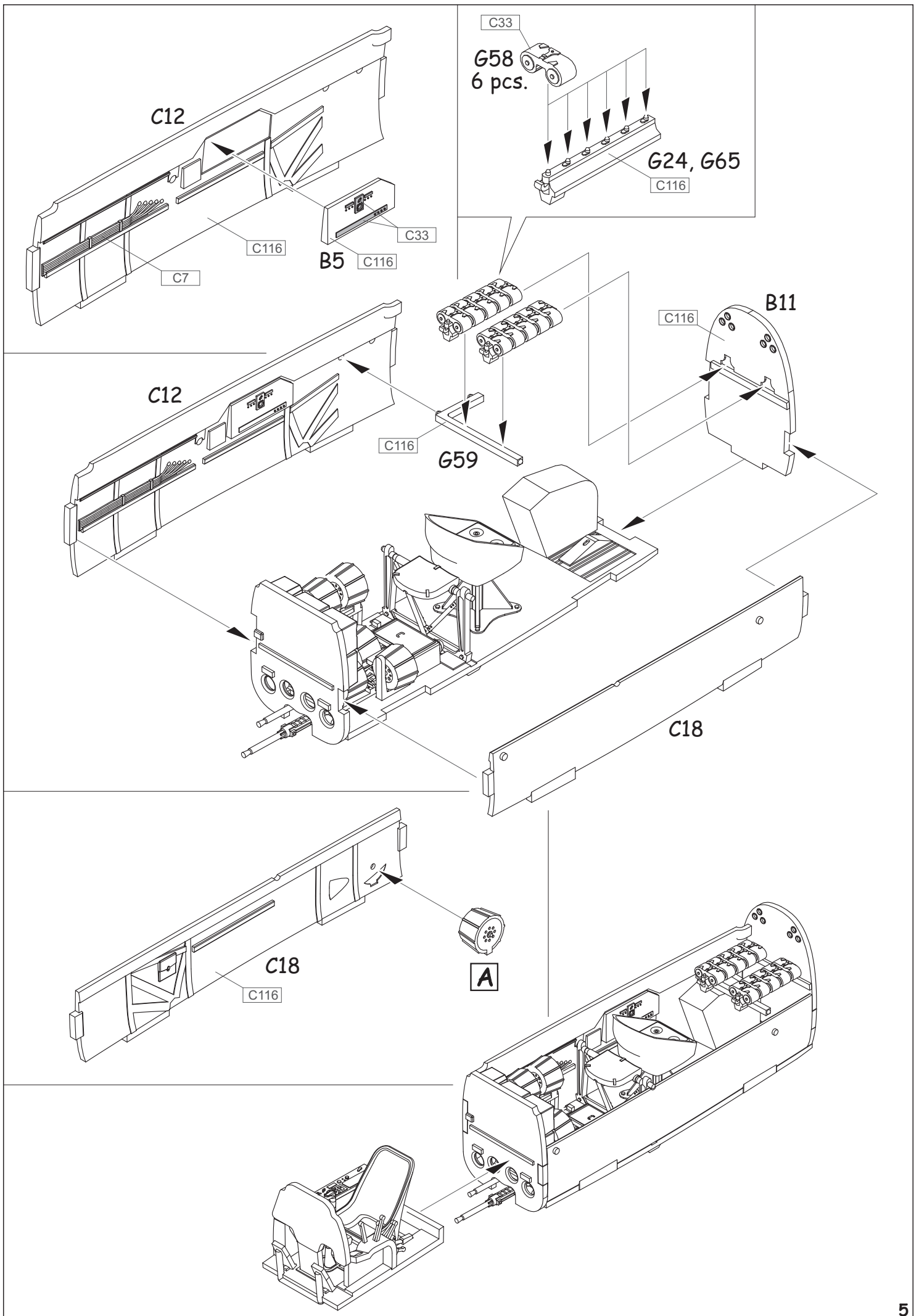

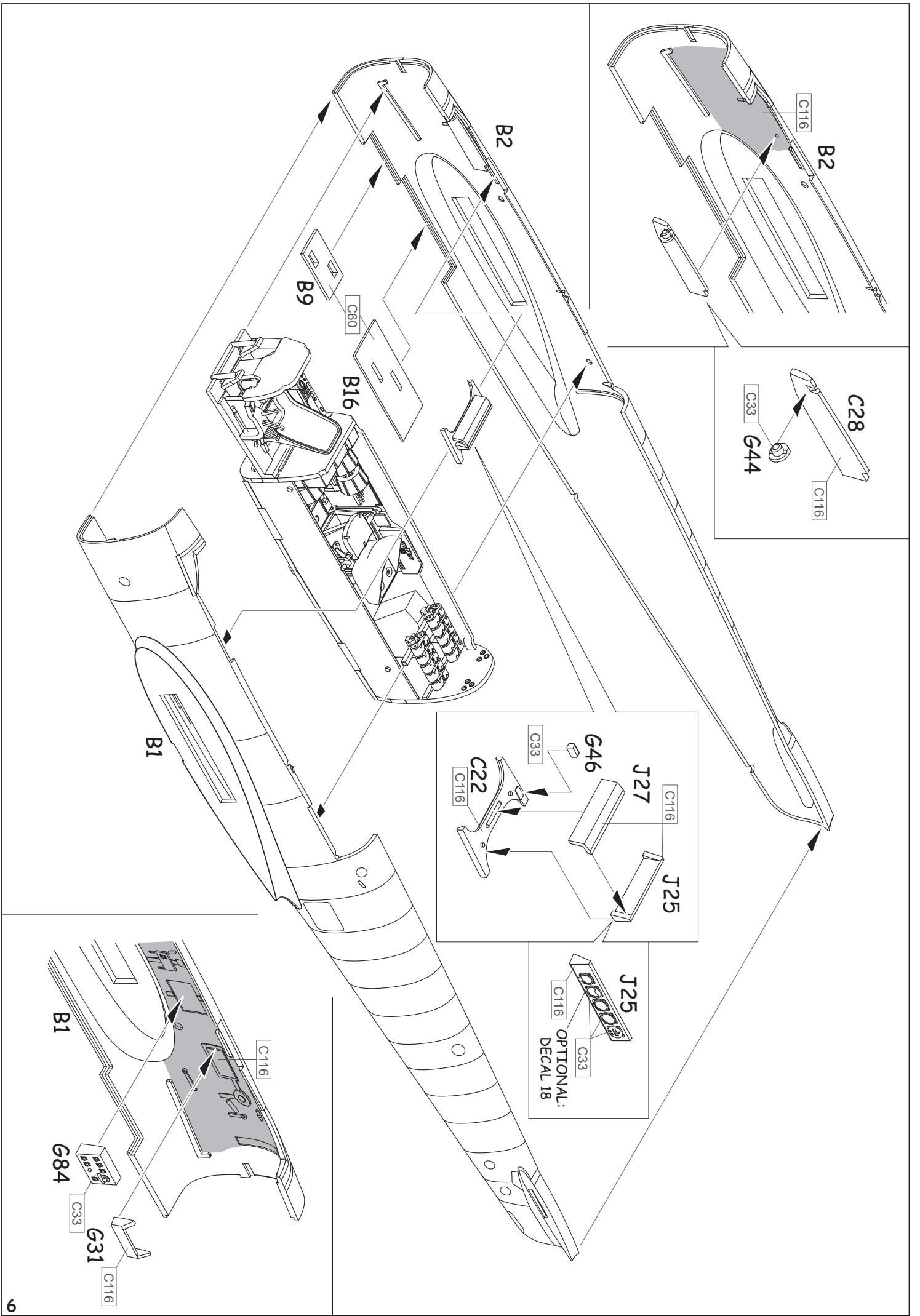

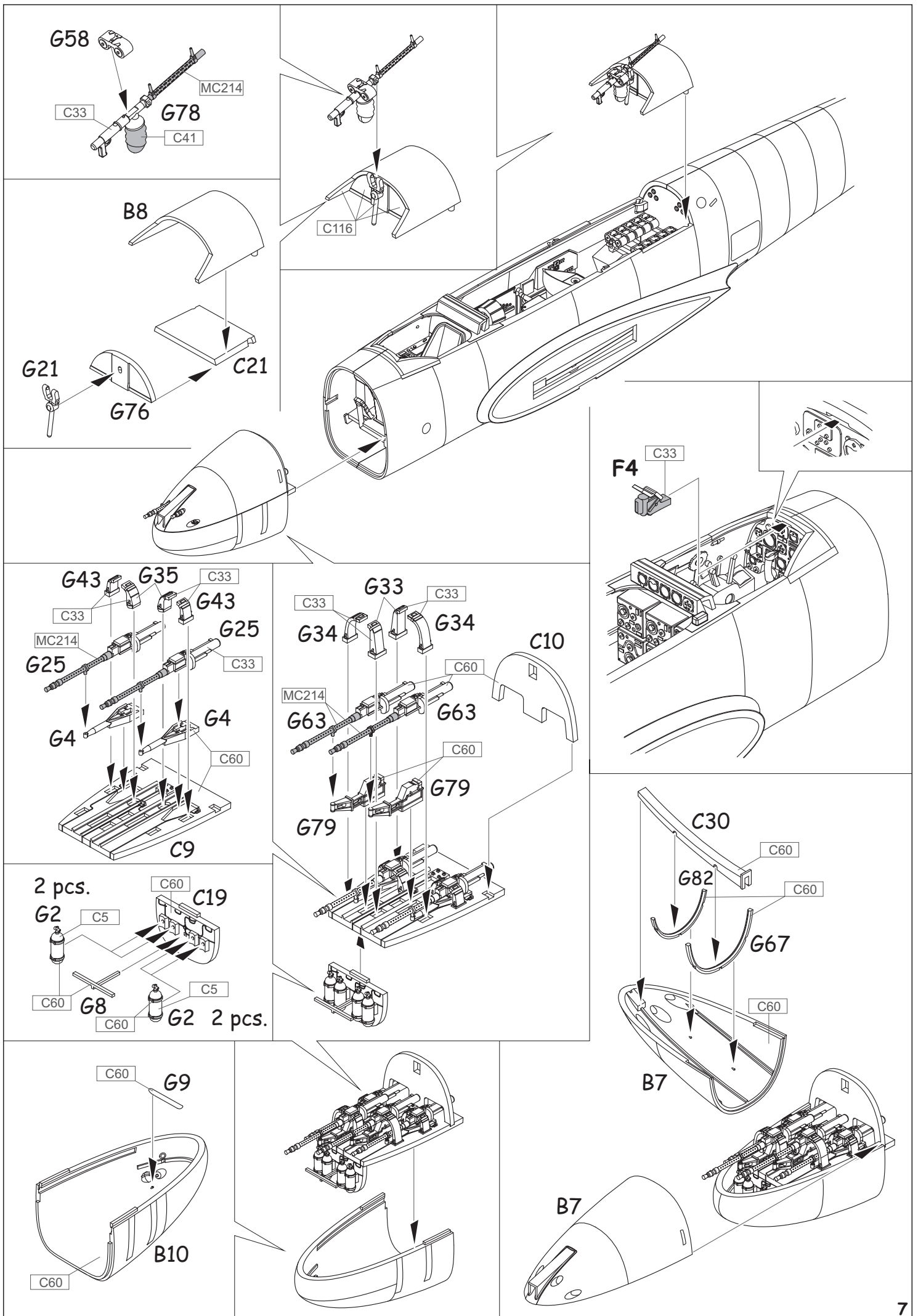

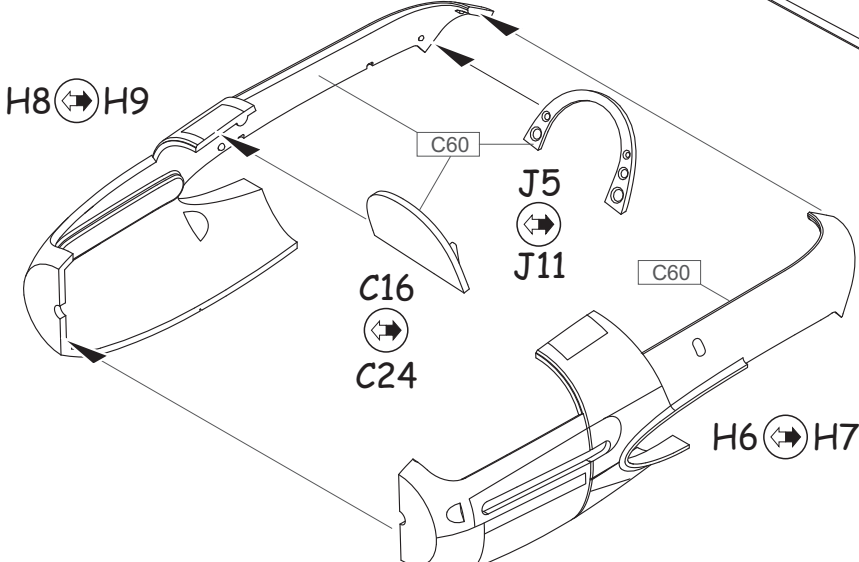
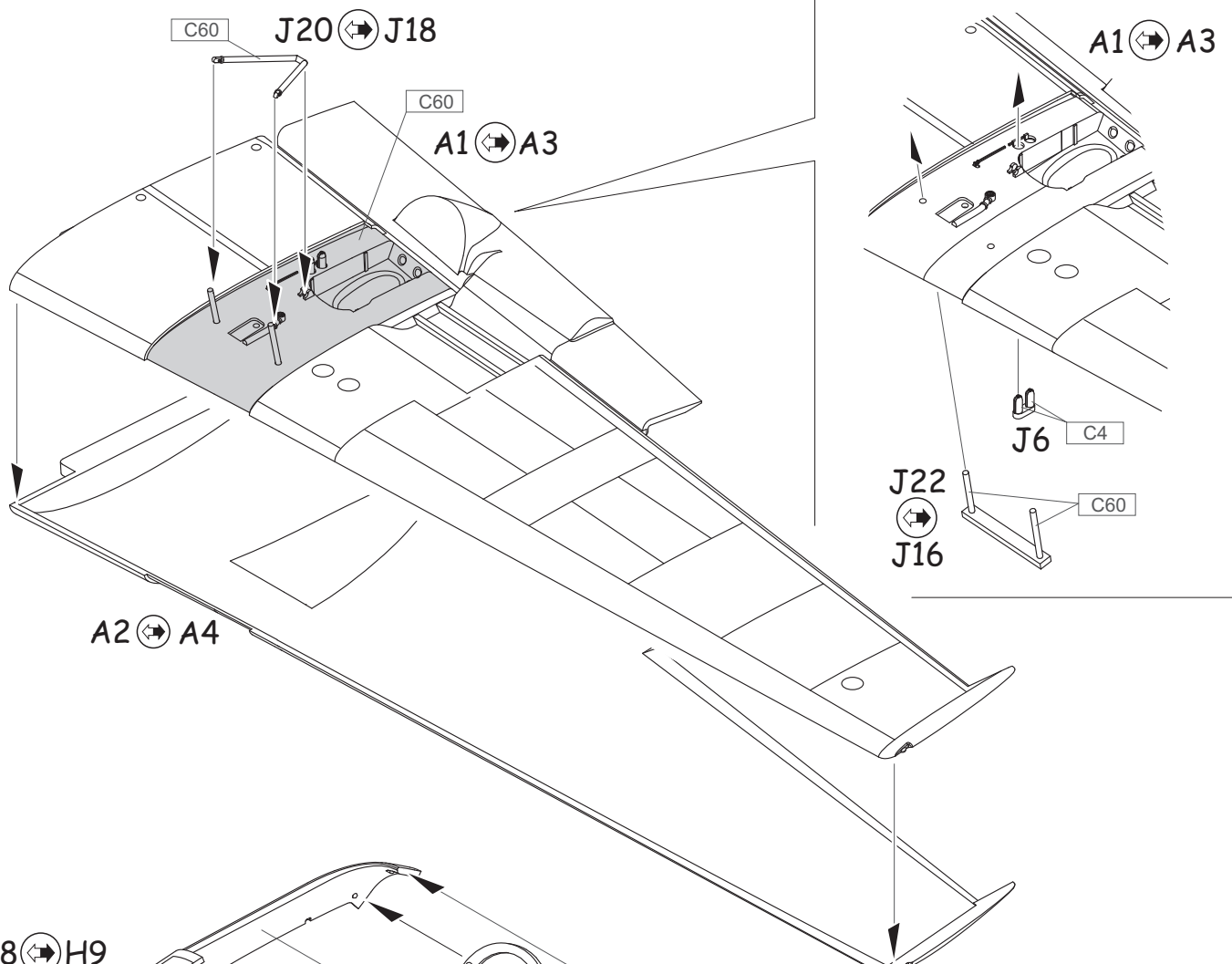
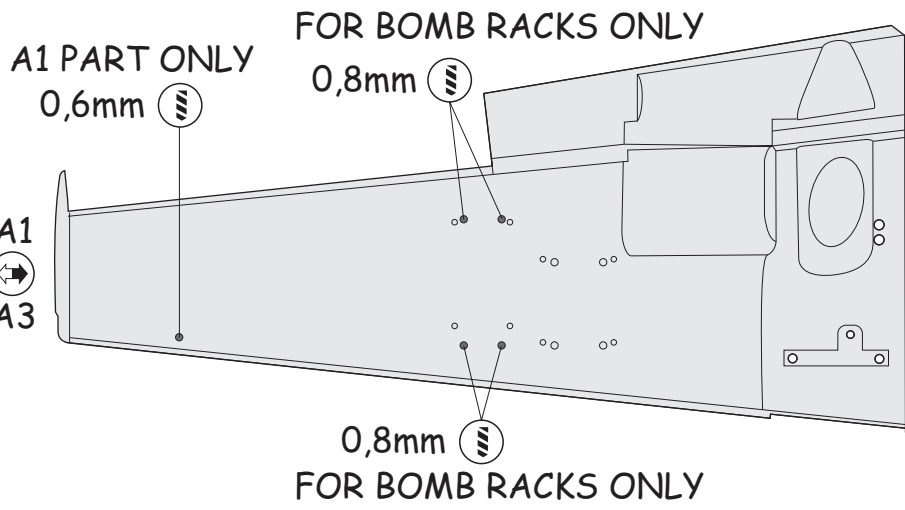

RIGHT - $\begin{matrix} H8+C36 \\ H6+C35 \end{matrix} \begin{matrix} > \\ > \end{matrix} C16+J5$

LEFT - $\begin{matrix} H9+C25 \\ H7+C26 \end{matrix} \begin{matrix} > \\ > \end{matrix} C24+J11$

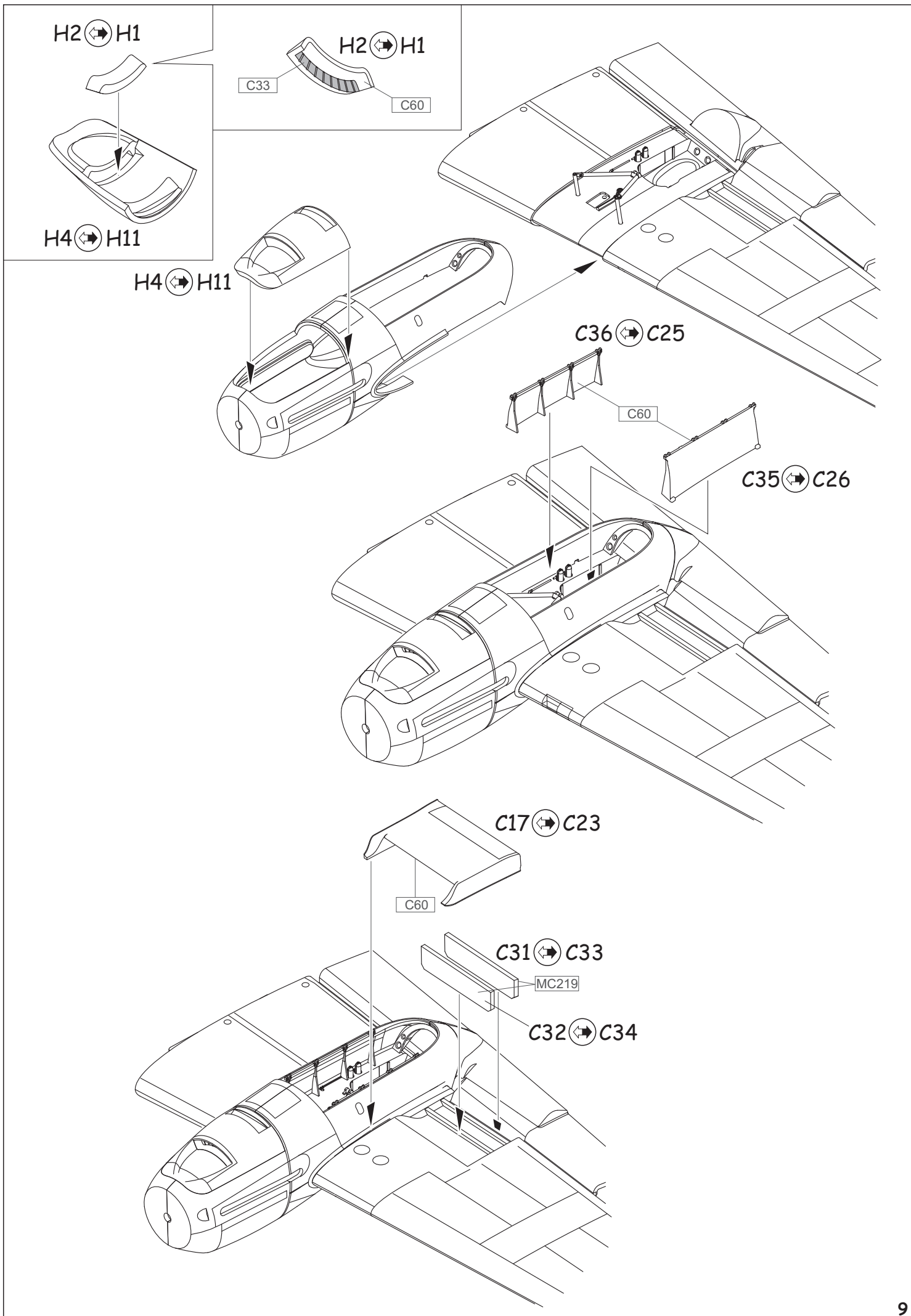

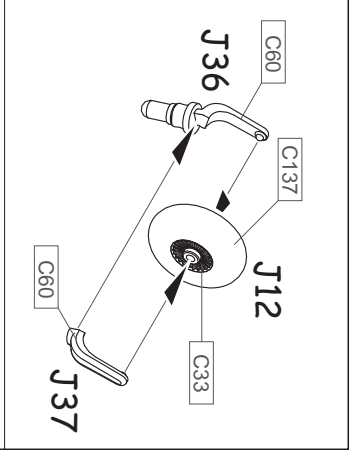
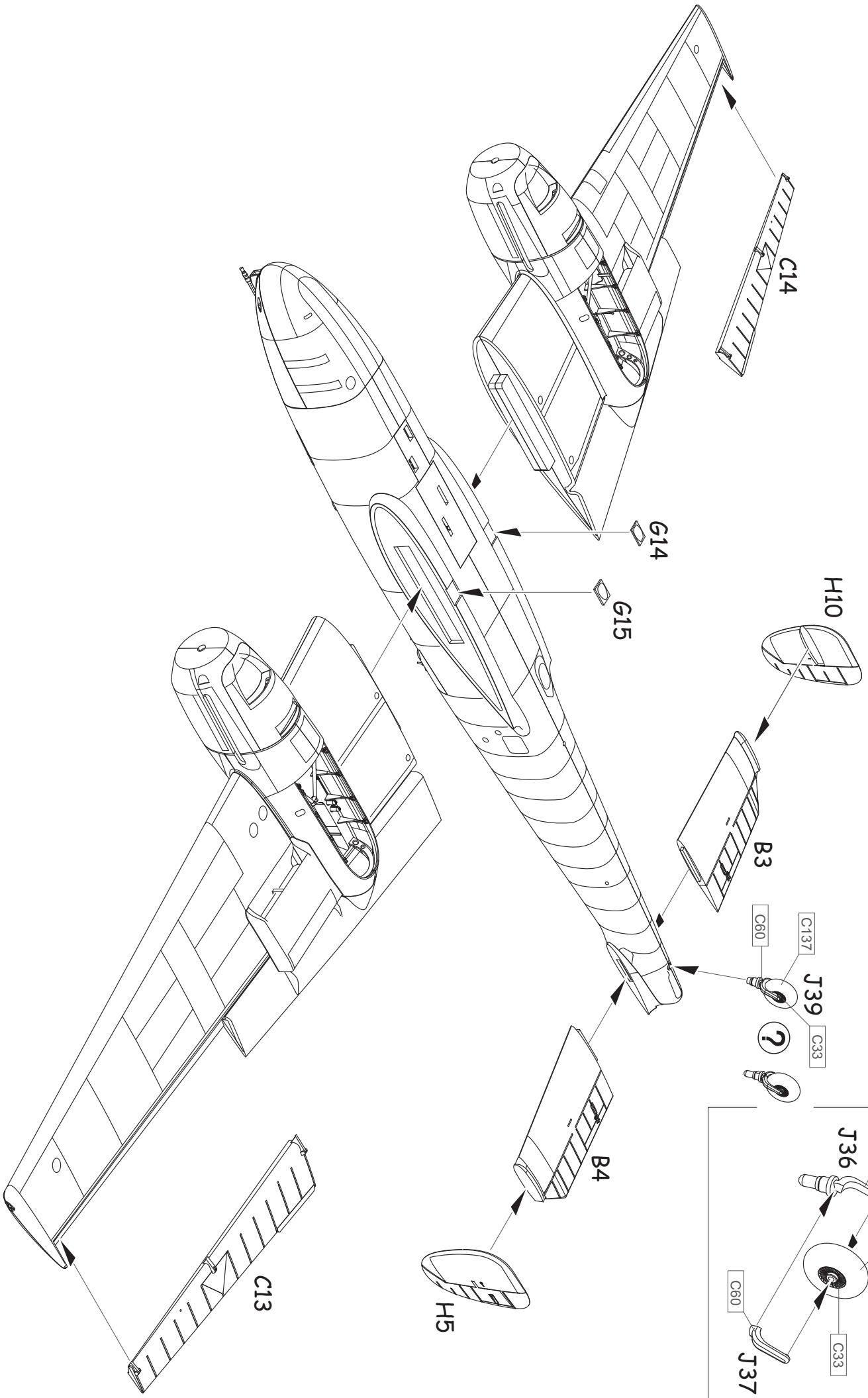

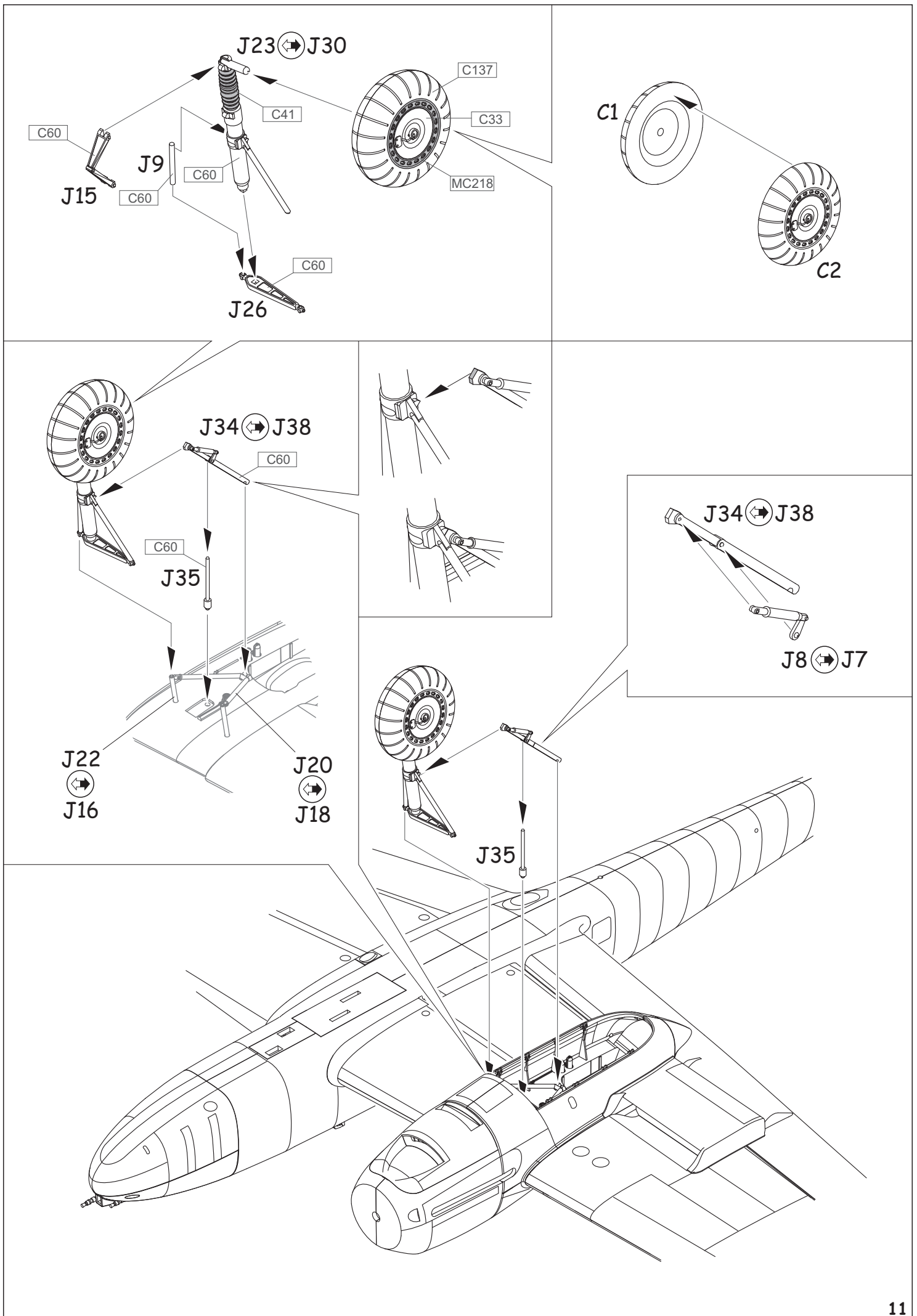

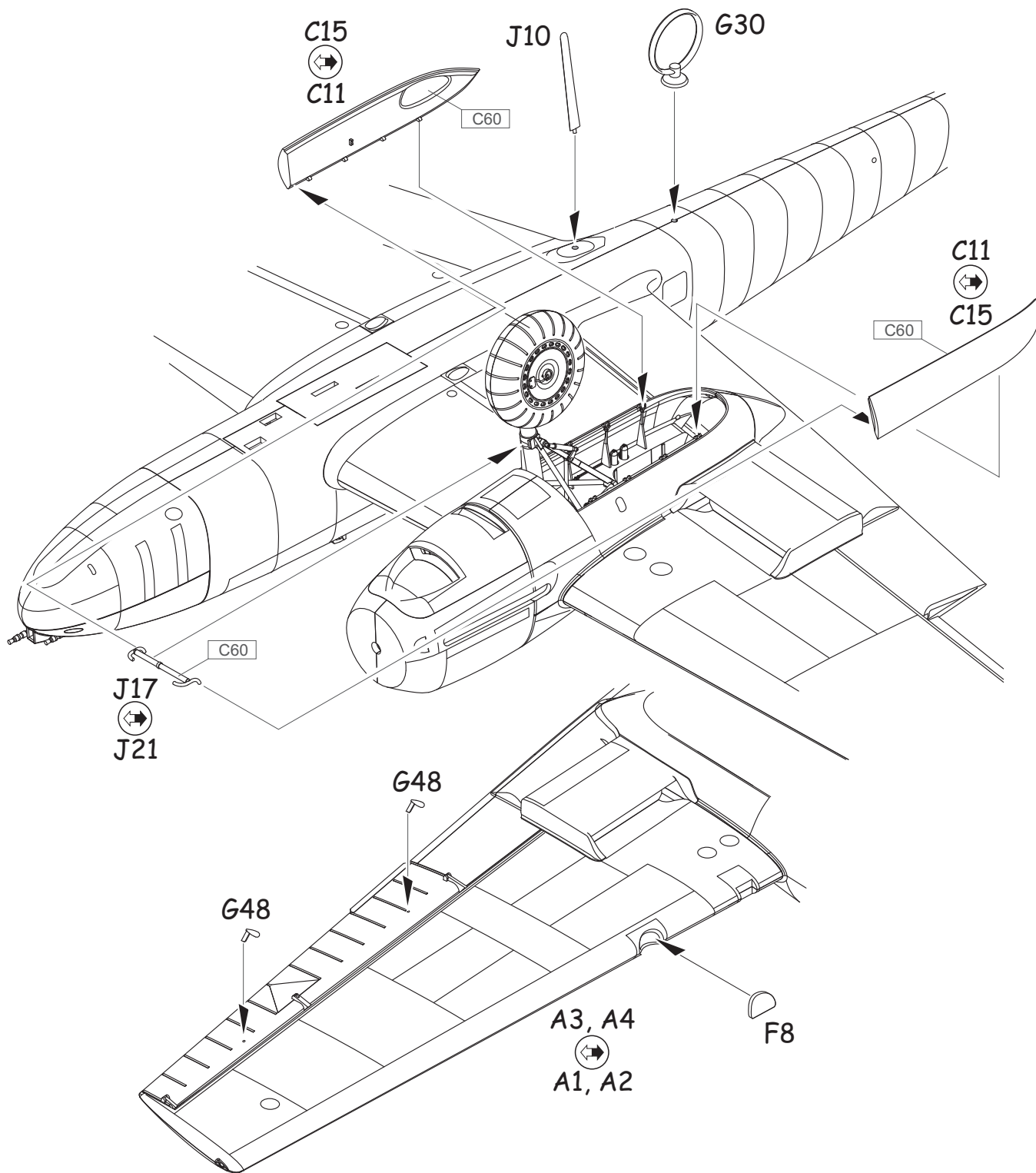

WE RECOMMEND TO GLUE J24/ J32 EXHAUST BASES TO ENGINE NACELLES FIRST, NEXT GLUE THE EXHAUST PIPES TO THE BASES.

DOPORUČUJEME NEJPRVE NALEPIT ZÁKLADNY VÝFUKŮ J24/ J32 DO MOTOROVÝCH GONDOL, TEPRVE POTÉ VLEPOVAT JEDNOTLIVÉ VÝFUKY SO SESTAVY.

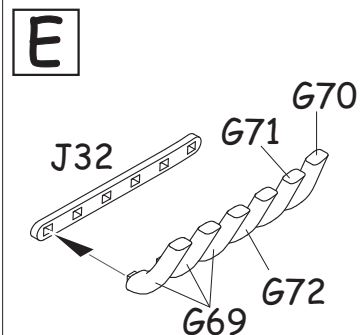
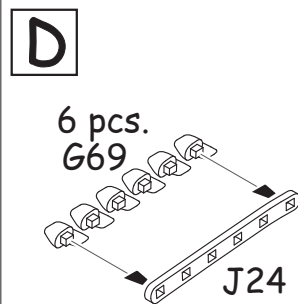
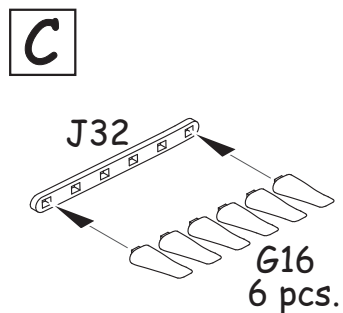
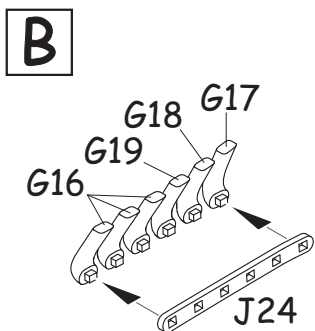

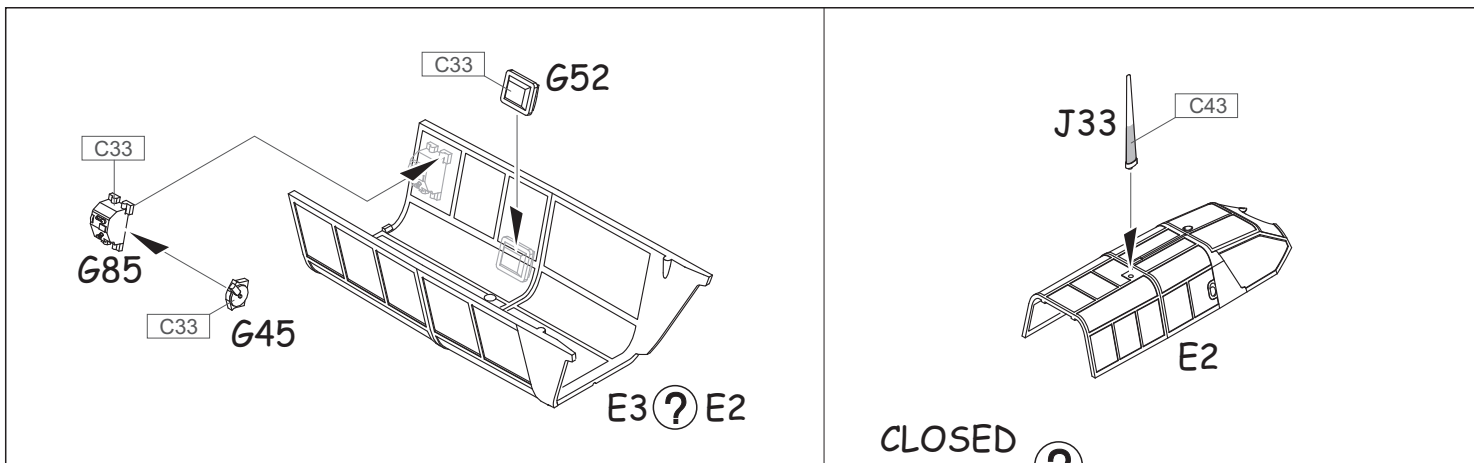

CLOSED ?
OPEN

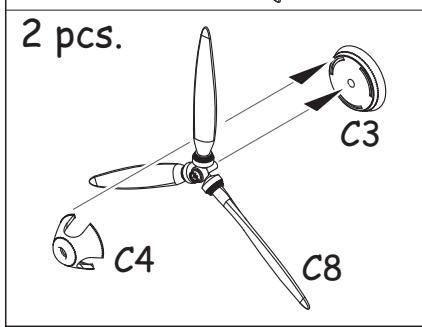
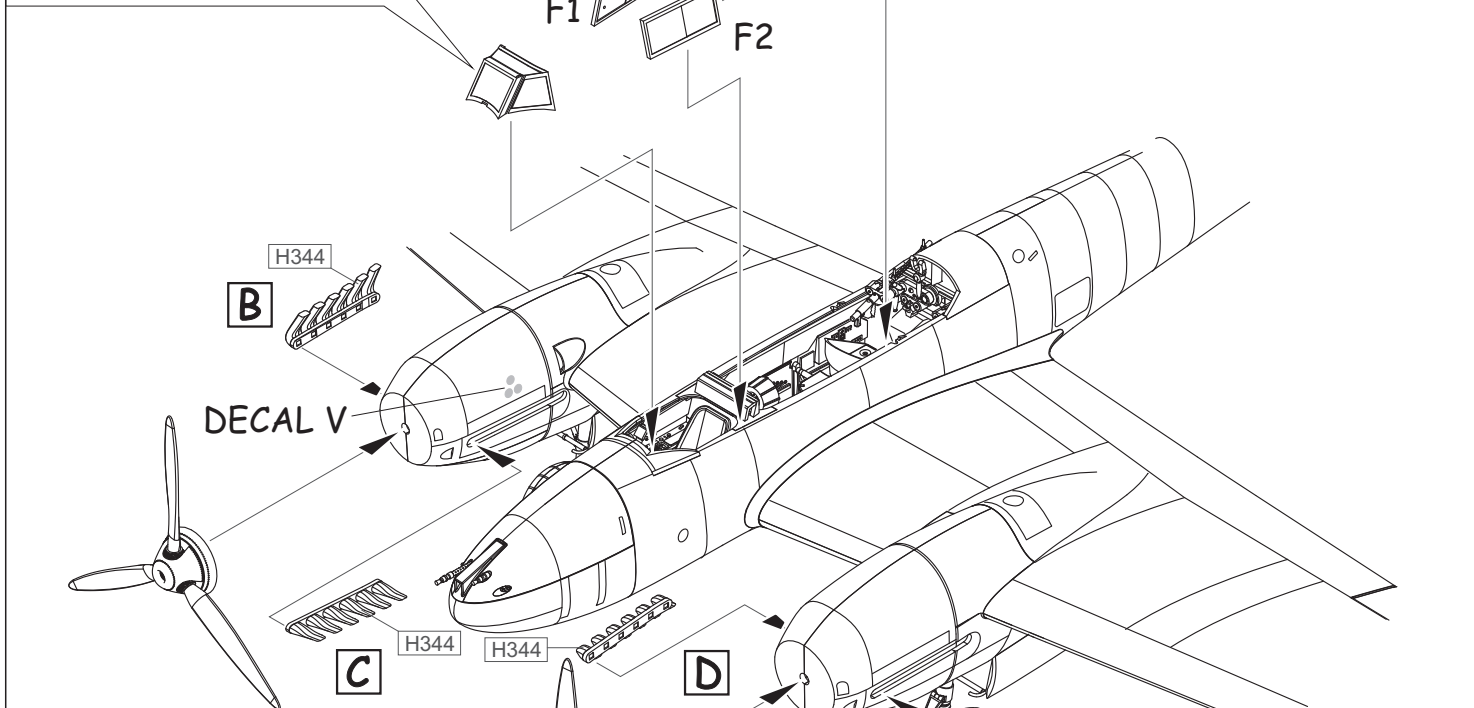
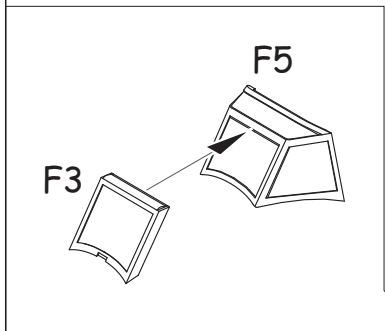
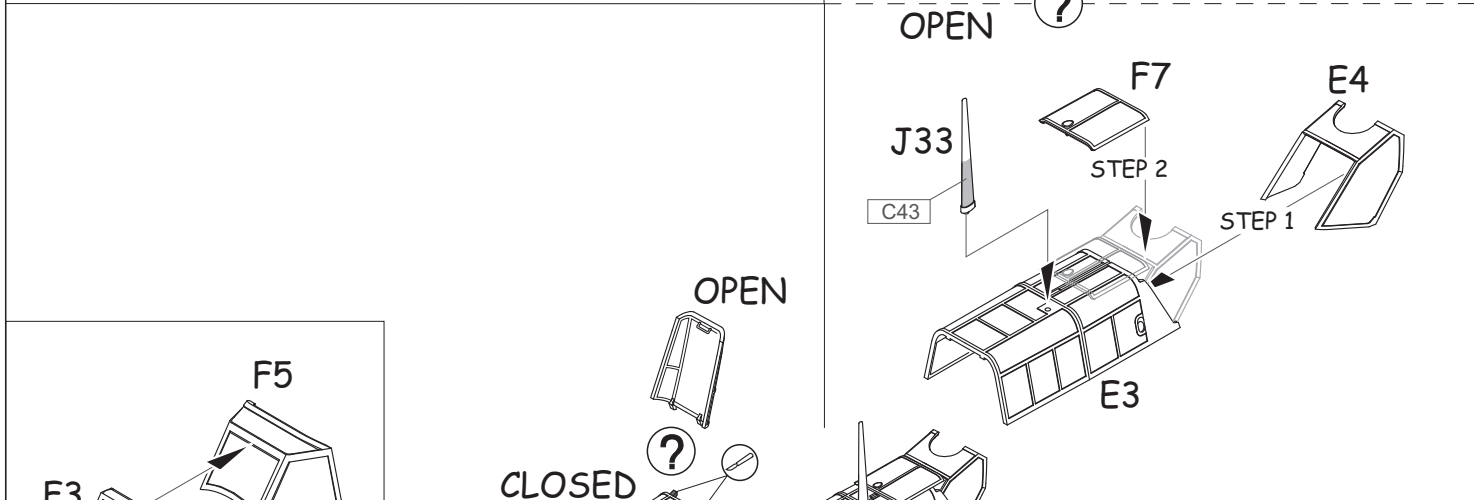

2 pcs.

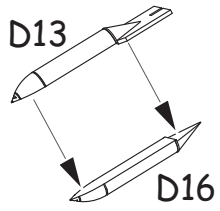

2 pcs.

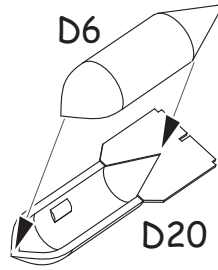

2 pcs.

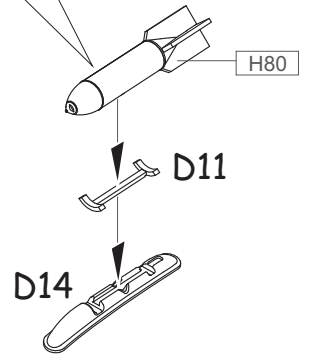
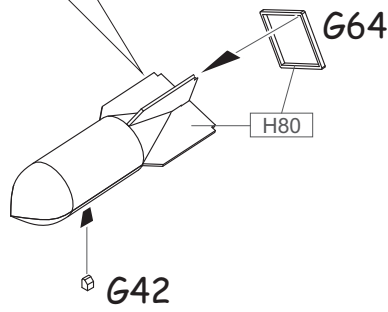
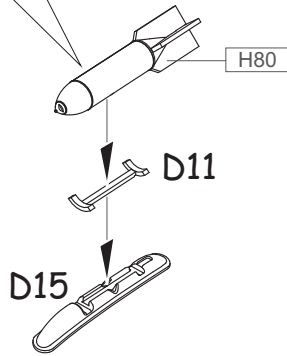
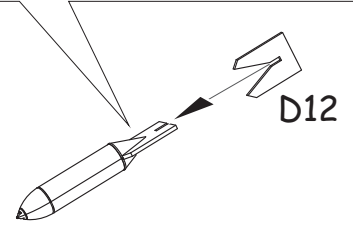
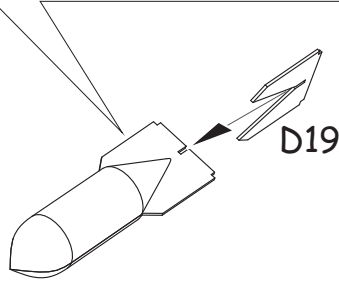
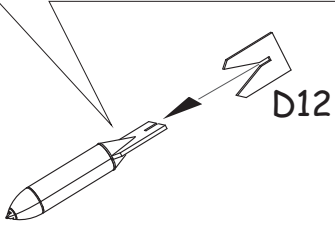
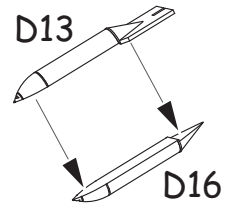

2 pcs.

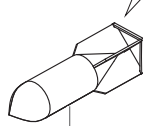
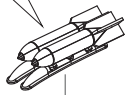

B13
DECAL K

2 pcs.

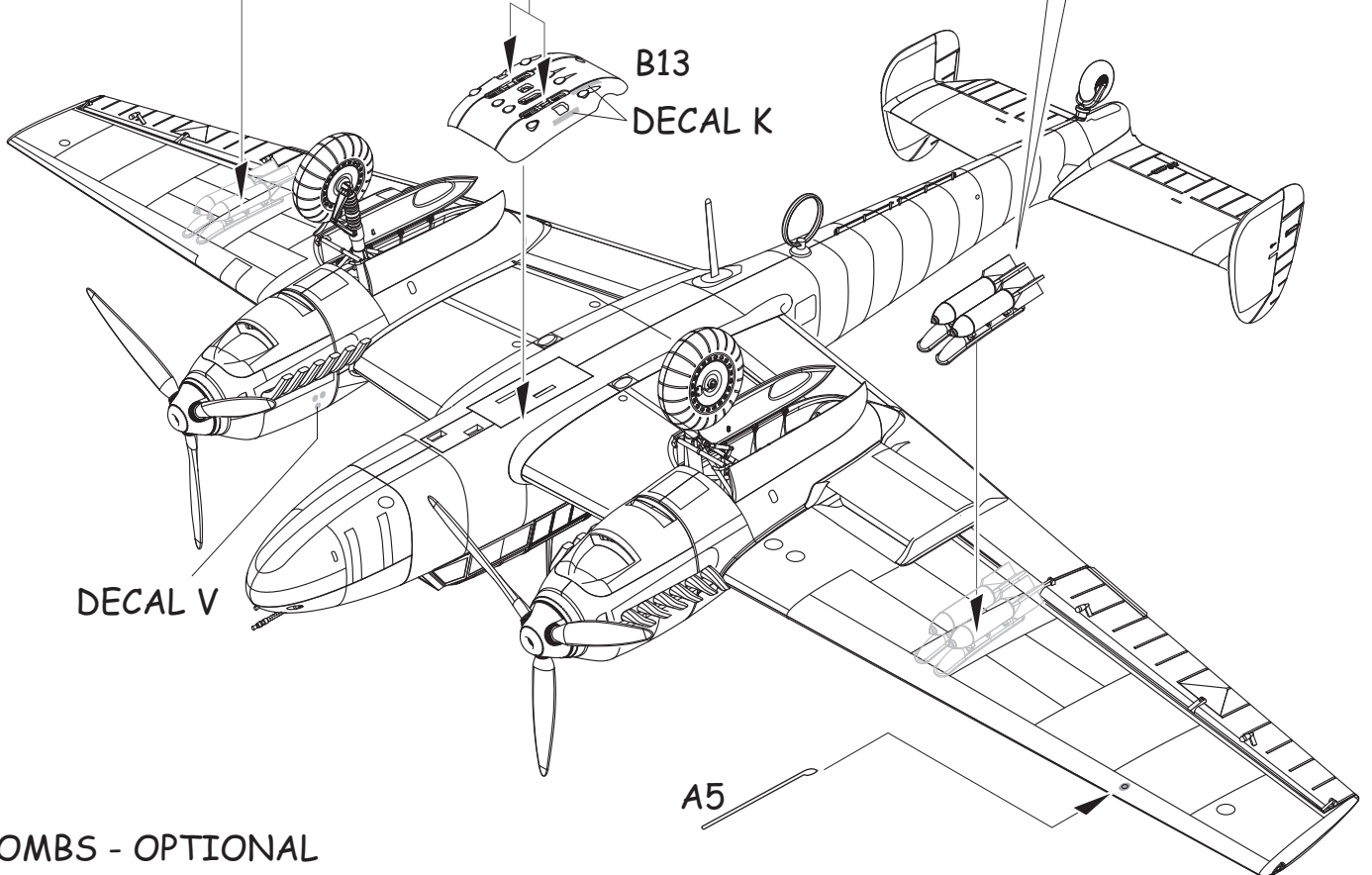

BOMBS - OPTIONAL

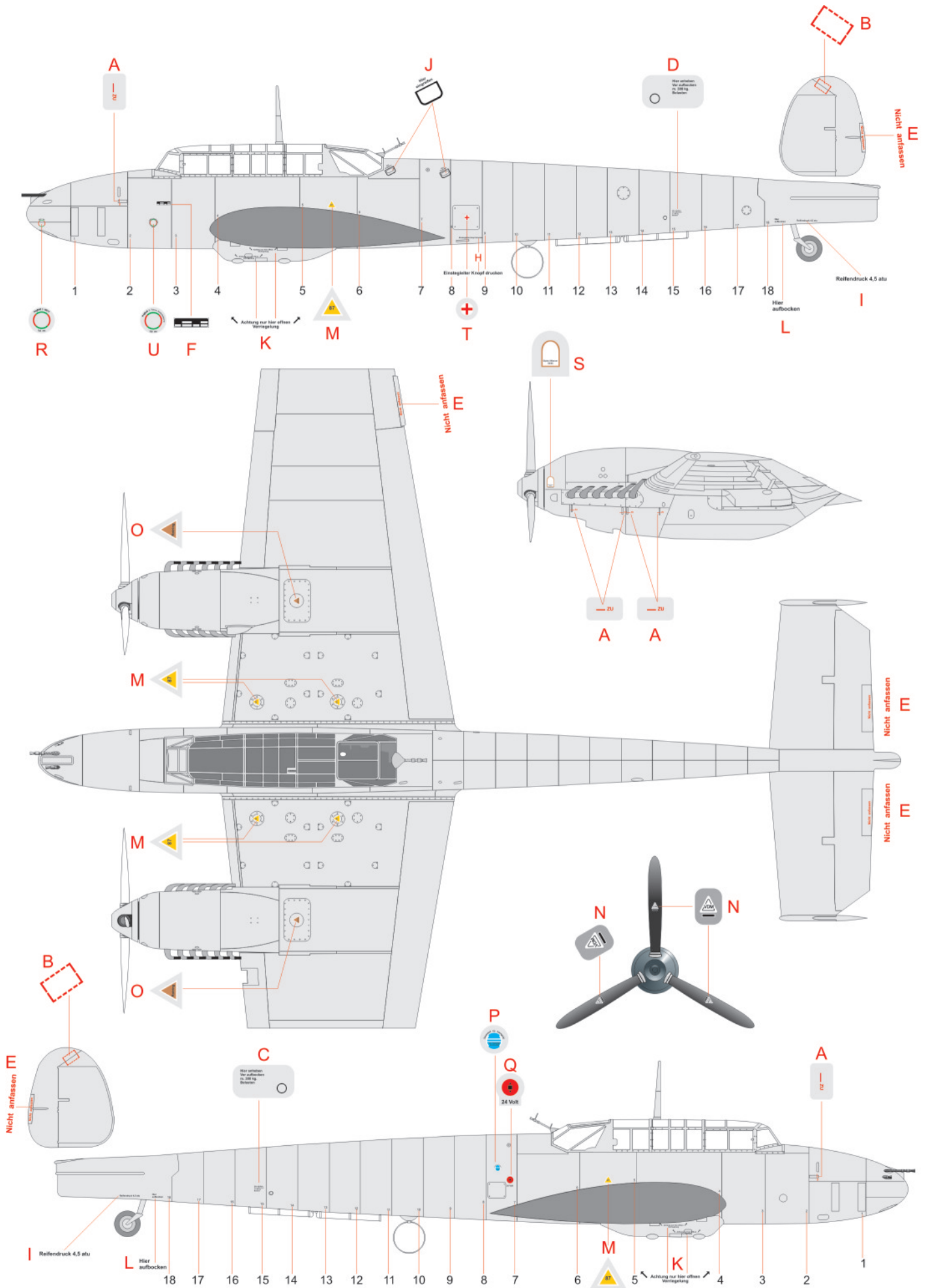

1.(Z)/JG 77, Lt. Felix-Maria Brandis, Malmi, Finland, 1942

One of the aircraft of 1.(Z)/JG 77 commander, Lt. Felix-Maria Brandis, while stationed on the Eastern Front. His credit count tallied 14 victories, of which five were British (including a pair of Fairey Albacores) and nine Soviet aircraft. Lt. Brandis died on February 2, 1942 flying Bf 110E-2 (W.Nr. 2546) LN+AR at Olang, when he crashed on the return leg of a combat sortie during bad weather. By that time, his unit had been re-designated 6.(Z)/JG 5 (January 25, 1942). The designation of the unit progressively changed from 1.(Z)/JG 77 to 6.(Z)/JG 5, 10.(Z)/JG 5 and 13.(Z)/JG 5. On the nose of the aircraft, there was the emblem of a dachshund with a Rata (Polikarpov I-16) in its mouth. For this unit, this was a characteristic marking, because a number of these dogs were mascots of the "Dackelstaffel" over the length of its existence, irrespective of the unit designation carried at any particular time. Some sources even say each crew had their own dog. The Wiener dogs even occasionally flew on combat missions with the crew. The unit opposed British aircraft, as well as Soviet, in northern Europe. This aircraft, along with Lt. Harry Kripphal, fell on June 18, 1942, a victim of anti-aircraft fire 30 km west of Murmansk.

Jeden ze strojů velitele 1.(Z)/JG 77, poručíka Felixe-Maria Brandise, během jeho působení na východní frontě. Na jeho kontě bylo celkem 14 vítězství, z toho 5 britských (včetně 2 Fairey Albacore) a 9 sovětských letounů. Lt. Brandis zahynul 2. února 1942 se strojem Bf 110 E-2 (W.Nr. 2546) LN+AR u Olangy, když jeho letoun při návratu z bojového letu ve špatném počasí narazil do terénu. V tu dobu už byla jeho jednotka přejmenována na 6.(Z)/JG 5. Označení jednotky se postupně měnilo z 1.(Z)/JG 77 na 6.(Z)/JG 5, 10.(Z)/JG 5 a 13.(Z)/JG 5. Na přední letounu byl znak jezevčička s Ratou (Polikarpov I-16) v tlamě. Pro tuto jednotku je emblém jezevčička charakteristický. Dva jezevčičí byli maskoty "Dackelstaffel" po celou dobu její existence, bez ohledu na označení, které právě nesla. Jezevčiči někdy dokonce s osádkami absolvovali i bojové lety. Jednotka byla na severu Evropy nasazena jak proti britským, tak i proti sovětským letounům. Tento stroj, i s osádkou Lt. Harry Kripphala, padl dne 18. června 1942 za oběť protiletadlové palbě 30 km západně od Murmansku.

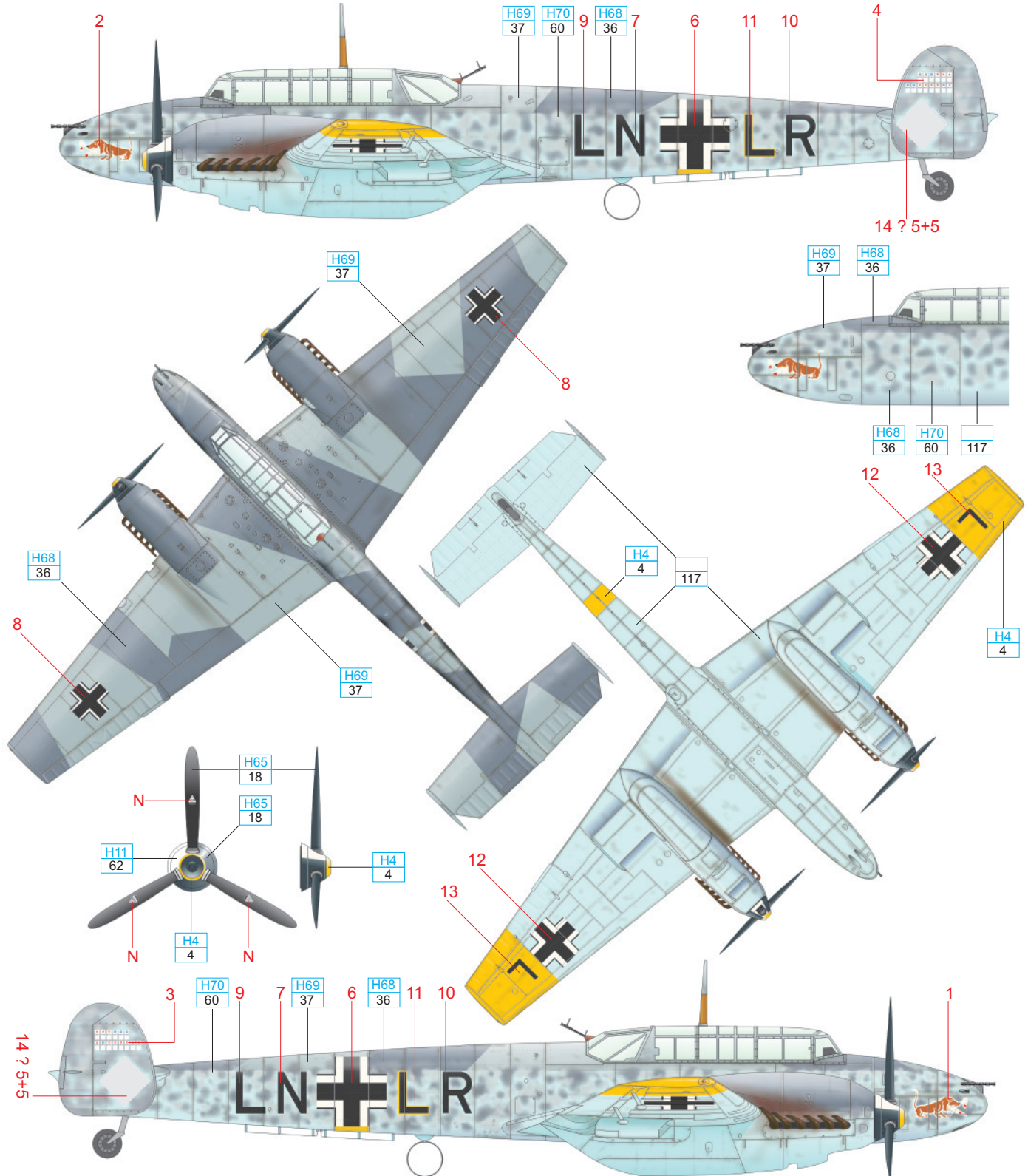

WHITE H11 62 YELLOW H4 4

RLM 76 117 RLM 02 H70 60 RLM 75 H69 37 RLM 74 H68 36 RLM 70 H65 18

eduard